

DEPARTMENT OF THE ARMY TECHNICAL MANUAL

OPERATOR'S ORGANIZATIONAL AND DIRECT SUPPORT
MAINTENANCE MANUAL

TENT, FRAME TYPE, SECTIONAL, ALL-WEATHER HOUSING,
WITH DOOR AND WINDOW ASSEMBLIES, WOOD FLOOR
DIMENSIONS 16 FT. LONG, 16 FT. WIDE (MODEL M-1948)
(FSN 8340-262-2399)

**This reprint includes all changes in effect at the
time of publication - Change 1.**

HEADQUARTERS, DEPARTMENT OF THE ARMY
JUNE 1965

SAFETY PRECAUTIONS

Do not attempt repair to electric wiring or switches prior to disconnecting the main power line. Avoid contact with a charged power line. The charge could result in personnel injury or loss of life.

Change }
No. 1 }

HEADQUARTERS
DEPARTMENT OF THE ARMY
WASHINGTON, D.C., 27 April 1973

**Operator, Organizational, and Direct Support Maintenance Manual
TENT, FRAME-TYPE, SECTIONAL, ALL-WEATHER HOUSING,
WITH DOOR AND WINDOW ASSEMBLIES, WOOD FLOOR,
DIMENSIONS 16 FT. LONG, 16 FT. WIDE (MODEL M-1948)
FSN 8340-262-2399**

TM 10-8340-210-13, 7 June 1965, is changed as follows:
Page 47. Appendix II is superseded as follows:

APPENDIX II

**BASIC ISSUE ITEM LIST AND ITEMS
TROOP INSTALLED OR AUTHORIZED**

Section 1. INTRODUCTION

1. Scope

This appendix lists basic issue items, items troop installed or authorized which accompany the frame-type tent and are required by the crew/operator for operation, installation, or operator's maintenance.

2. General

This basic issue items, items troop installed or authorized list is divided into the following sections:

a. Basic Issue Items List-Section II. Not applicable.

b. Items Troop Installed or Authorized List - Section III. A list in alphabetical sequence of items which at the discretion of the unit commander may accompany the end item, but are NOT subject to be turned in with the end item.

3. Explanation of Columns

The following provides an explanation of columns in the tabular list of Basic Issue Items List, Section II, and Items Troop Installed or Authorized, Section III.

a. Source, Maintenance, and Recoverability Code(s) (SMR): Not applicable.

b. Federal Stock Number. This column indicates the federal stock number assigned to the item and will be used for requisitioning purposes.

c. Description. This column indicates the Federal item name and any additional description of the item required.

d. Unit of Measure (U/M). A 2 character alphabetic abbreviation indicating the amount or quantity of the item upon which the allowances are based, e.g., ft, ea, pr, etc.

e. Quantity Authorized (Items Troop Installed or Authorized Only). This column indicates the quantity of the item authorized to be used with the equipment.

**Operators, Organizational, and Direct
 Support Maintenance Manual**

**TENT, FRAME-TYPE, SECTIONAL, ALL-WEATHER
 HOUSING, WITH DOOR AND WINDOW ASSEMBLIES,
 WOOD FLOOR, FLOOR DIMENSIONS 16 FT. LONG,
 16 FT. WIDE (MODEL M-1948)
 (FSN 8340-262-2399)**

CHAPTER	1.	INTRODUCTION		
Section	I.	General	1-5	3
	II.	Description and Data	6-7	3
CHAPTER	2.	USING INSTRUCTIONS		
Section	I.	Service Upon Receipt of Equipment	8-9	7
	II.	Use Under Usual Conditions	10-14	10
	III.	Use Under Unusual Conditions	15-16	19
CHAPTER	3.	USER AND ORGANIZATIONAL MAINTENANCE INSTRUCTIONS		
Section	I.	Tools and Equipment	17-18	21
	II.	Preventive Maintenance Services Under Usual and Unusual Conditions	19-21	21
	III.	Tent Body	22-25	23
	IV.	Tent Support Components	26-30	26
	V.	Tent Anchoring Components	31-34	29
	VI.	Tent Accessories	35-37	30
CHAPTER	4.	DIRECT SUPPORT MAINTENANCE INSTRUCTIONS		
Section	I.	Tent Body	38-41	32
	II.	Tent Support Components	42-46	37
	III.	Tent Anchoring Components and Tent Accessories	47,48	40
CHAPTER	5.	SHIPMENT AND LIMITED STORAGE AND DEMOLITION TO PREVENT ENEMY USE		
Section	I.	Shipment Within CONUS.....	49-51	43
	II.	Limited Storage	52-54	43
	III.	Demolition of Materiel to Prevent Enemy Use	55,56	44
APPENDIX	I.	REFERENCES		45
	II.	BASIC ISSUE ITEMS LIST AND MAINTENANCE AND OPERATING SUPPLIES.....		47
	III.	MAINTENANCE ALLOCATION CHART		49
INDEX			52

* This manual, together with TM 10-840210-23P, 19 March 1964, supersedes TM ,0-16, 1 September 1949, in its entirety, including C 1 112 February 1951, and C 2, May 1956.

CHAPTER 1
INTRODUCTION

Section I. GENERAL

1. Scope

a. This manual is for the use of personnel responsible for the use (erecting and striking), organizational maintenance, and direct support maintenance of the Tent, Frame-Type, Sectional, M-1948, FSN 8340-262-2399.

b. It provides the user and maintenance personnel with the necessary instructions to use the tent and to perform all required maintenance services. These maintenance services have been assigned within the limits of the maintenance allocation chart (app. III).

2. Appendixes

a. Appendix I contains a list of current references.

b. Appendix II contains the basic issue items list.

c. Appendix III contains the maintenance allocation chart.

3. Maintenance Forms, Records, and Reports

The maintenance forms, records, and reports applicable to both organization and direct support maintenance of this tent or listed and described in TM 38-750.

4. Reporting of Improvements

The direct reporting of errors, omissions, and recommendations for improving this manual by the individual user is authorized and encouraged. DA Form 2028 (Recommended Changes to DA Publications) will be used for reporting these improvements. This form will be completed in triplicate using pen, pencil, or typewriter and will be forwarded direct to Commanding General, U.S. Army Mobility Equipment Center, ATTN: SMOME-MMP, 4300 Goodfellow Boulevard, St. Louis, Missouri 63120.

5. Orientation

Throughout this manual, the use of terms *right*, *left*, *front*, and *rear* indicates directions from the viewpoint of the user facing the outside of the tent door on the end with the vestibule.

Section II. DESCRIPTION AND DATA

6. Description

a. The sectional, frame-type tent is designed to be a general purpose tent in cold climates. The tent length is expandable in multiples of four feet. It is stocked and issued in combinations of complete end sections, complete vestibule assemblies. Two end sections with any desired number of intermediate sections will form an insulated shelter. Although this

tent is issued in sections, the following information pertains to a complete 16 foot length.

b. The tent floor is composed of 8 insulated plywood floor units and 16 wooden floor runners. The wooden tent frame is composed of 5 arches and 36 arch purlins. Each of two end blanket assembly contains a door frame and door assembly, two window assemblies, and a transom. The tent roof cover is composed of

four insulated roof blanket assemblies and three guyband assemblies. The tent is equipped with 10 guy lines and 24 tent pins for anchoring it. The electrical connector switch is composed of a switch box, a cord, and four outlet boxes. The vestibule is composed of a wooden floor, a panel and door assembly, a side panel assembly, an end cover, and a top cover.

7. Tabulated Data

The tabulated data for this tent is contained in tables 1 and 2.

- a. Table 1 contains the data for the tent crates.
- b. Table 2 contains the data for the erected tent.

Table 1. Tent Packing Crates

Classification according to contents	Number per tent	Length (each)	Width (each)	Height (each)	Bulk (each)	Weight (pounds)	Components	
							Item	Number per crate
End section components	2	8 ft. 3 in.	4 ft. 1 in.	1 ft. 7 in.	50.0	500	End blanket assembly Tent lines End purlin Tent pin Floor unit Socket head key	1 ea 2 ea 2 ea 4 ea 2 ea 2 ea
Intermediate section components	2	8 ft. 3 in.	4 ft. 1 in.	1 ft. 7 in.	50.0	400	Roof blanket assembly Arch purlin Floor runner Guyband assembly Tent pin Floor unit Socket head key	2 ea 18 ea 8 ea 2 ea 8 ea 2 ea 2 ea
Vestibule	1	7 ft. 2 in.	4 ft. 0 in.	1 ft. 6 in.	43.0	328	End cover Top cover Panel and door assembly Side panel assembly Floor. Top purlin End purlin Tie angle	1 ea 1 ea 1 ea 1 ea 1 ea 1 ea 1 ea 1 ea
Roof arches	5	8 ft. 6 in.	0 ft. 5 in.	0 ft. 8 in.	2.3	50	Roof arch	5 ea
Electrical connector switch	1	1 ft. 6 in.	0 ft. 11 in.	0 ft. 7 in.	1.0	32	Electrical connector switch (complete)	1 ea

Table 2. Erected Tent Data

	Length	Width	Height	Area
Tent body:				
Outside	16 ft. 5 in.	16 ft. 9 in.	8 ft. 7 in.	275 sq. ft.
Inside	16 ft.	16 ft.	8 ft.	256 sq. ft.
Vestibule:				
Outside	3 ft. 11 in.	3 ft. 2 in.	7 ft. 2 in.	12 sq. ft.
Inside	3 ft. 10 in.	3 ft. 1 in.	6 ft. 6 in.	11 sq. ft.

CHAPTER 2
USING INSTRUCTIONS

Section I. SERVICE UPON RECEIPT OF EQUIPMENT

8. General

When a new or used tent is received by an organization it must be uncrated and inspected as

described in paragraph 9. These operations are performed to make certain all components are present and are in serviceable condition.

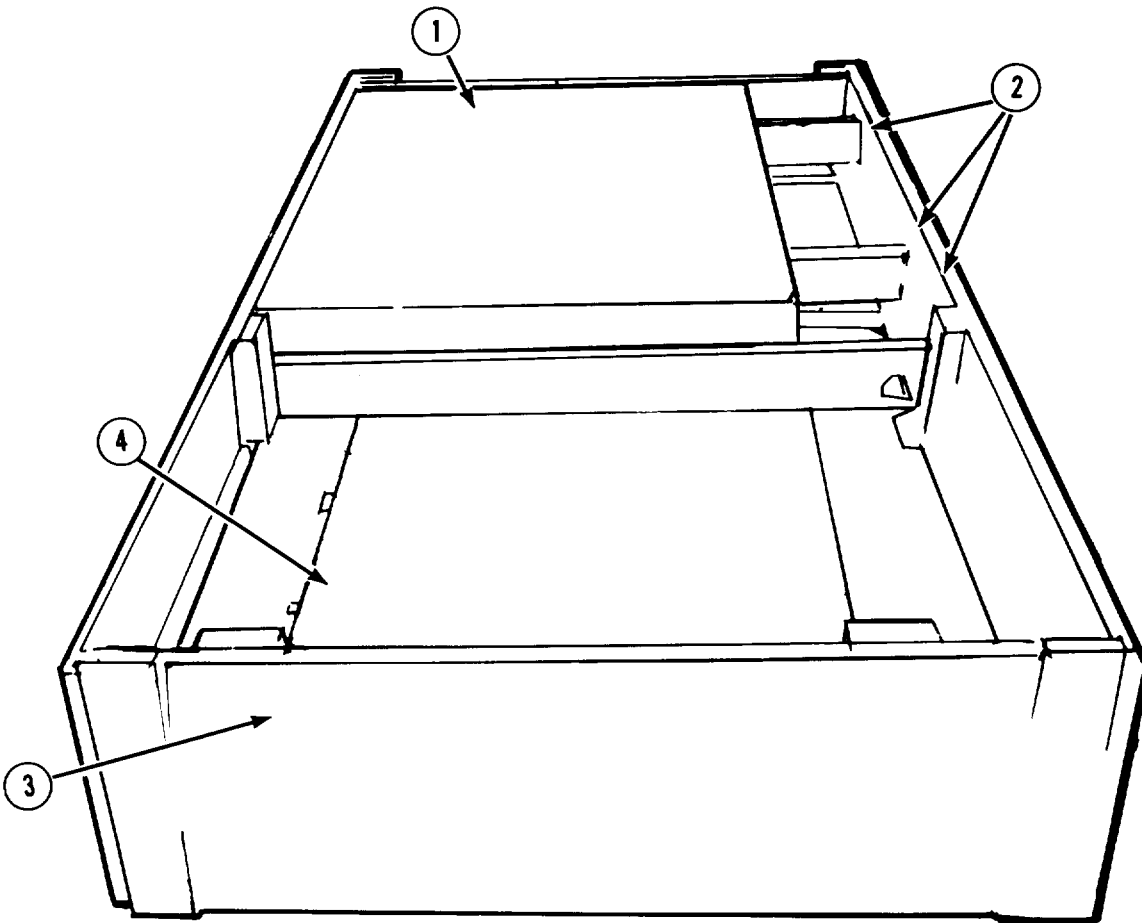

MEC 8340-210-13/1

- | | | | |
|---|------------------|---|-------------------------|
| 1 | Floor, vestibule | 3 | Crate, vestibule |
| 2 | Blocking | 4 | Panel and door assembly |

Figure 1. Vestibule crate with top removed.

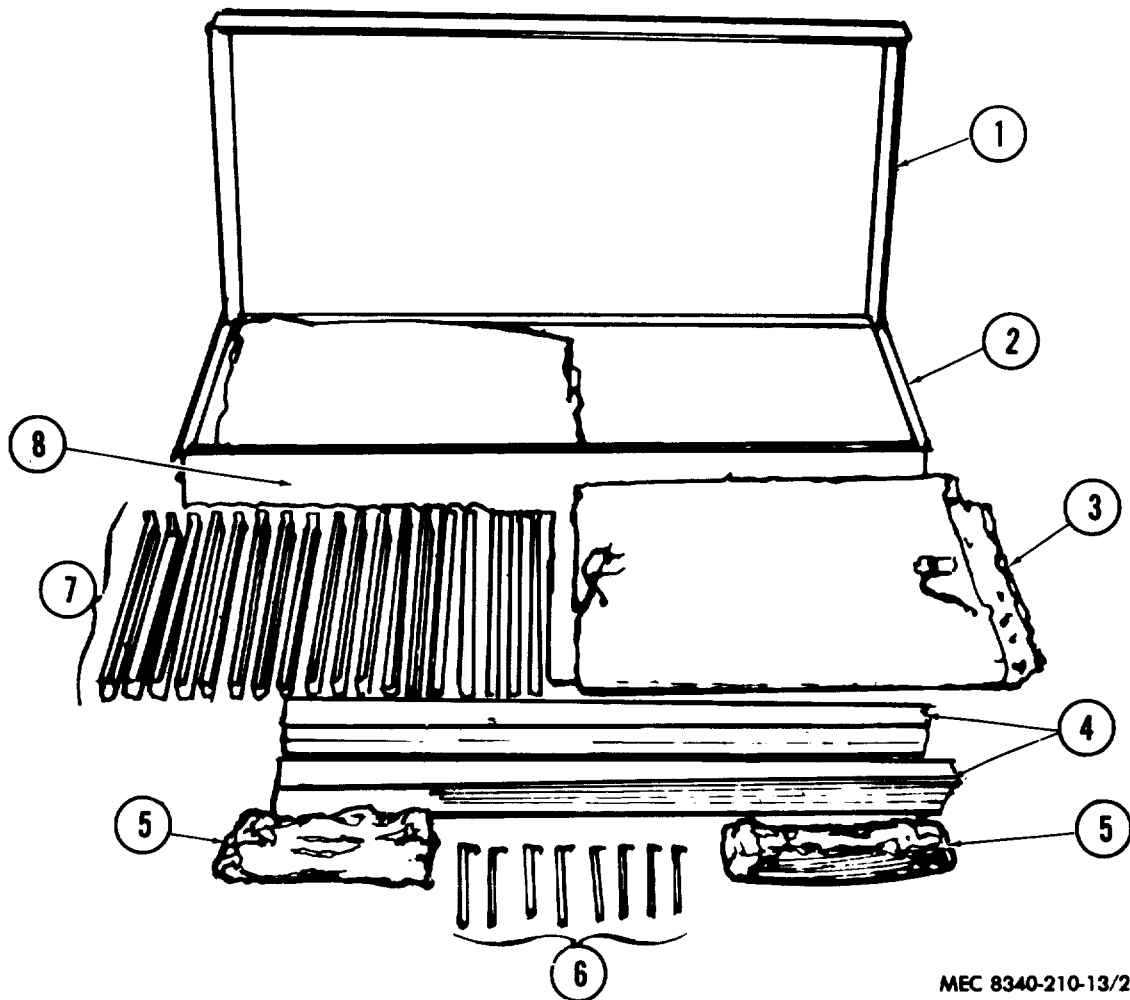

MEC 8340-210-13/2

- | | | | | | |
|---|------------------------|---|---------------------|---|------------------------|
| 1 | Floor unit, tent | 4 | Floor runners, tent | 7 | Purlins, tent arch |
| 2 | Floor unit, tent | 5 | Guyband assemblies | 8 | Key, socket head screw |
| 3 | Blanket assembly, roof | 6 | Pins, tent | | |

Figure 2. Intermediate section packing crate and components.

9. Uncrating and Inspecting the Tent

a. Uncrating.

- (1) Remove the top from the vestibule crate (3, fig. 1), and remove the crate and blocking (2) from around the vestibule components.
- (2) Remove the vestibule floor (1) from the panel and door assembly (4). Remove the tie angle, vestibule top purlin, vestibule end purlin, end cover,

and top cover from the panel and door assembly.

- (3) Remove the panel and door assembly from the side panel assembly, and remove the side panel assembly from the crate bottom.
- (4) Remove the electrical connector switch from its packing crate.
- (5) The eight floor sections of the box make up the remaining four crates. The floor sections are fully inter-

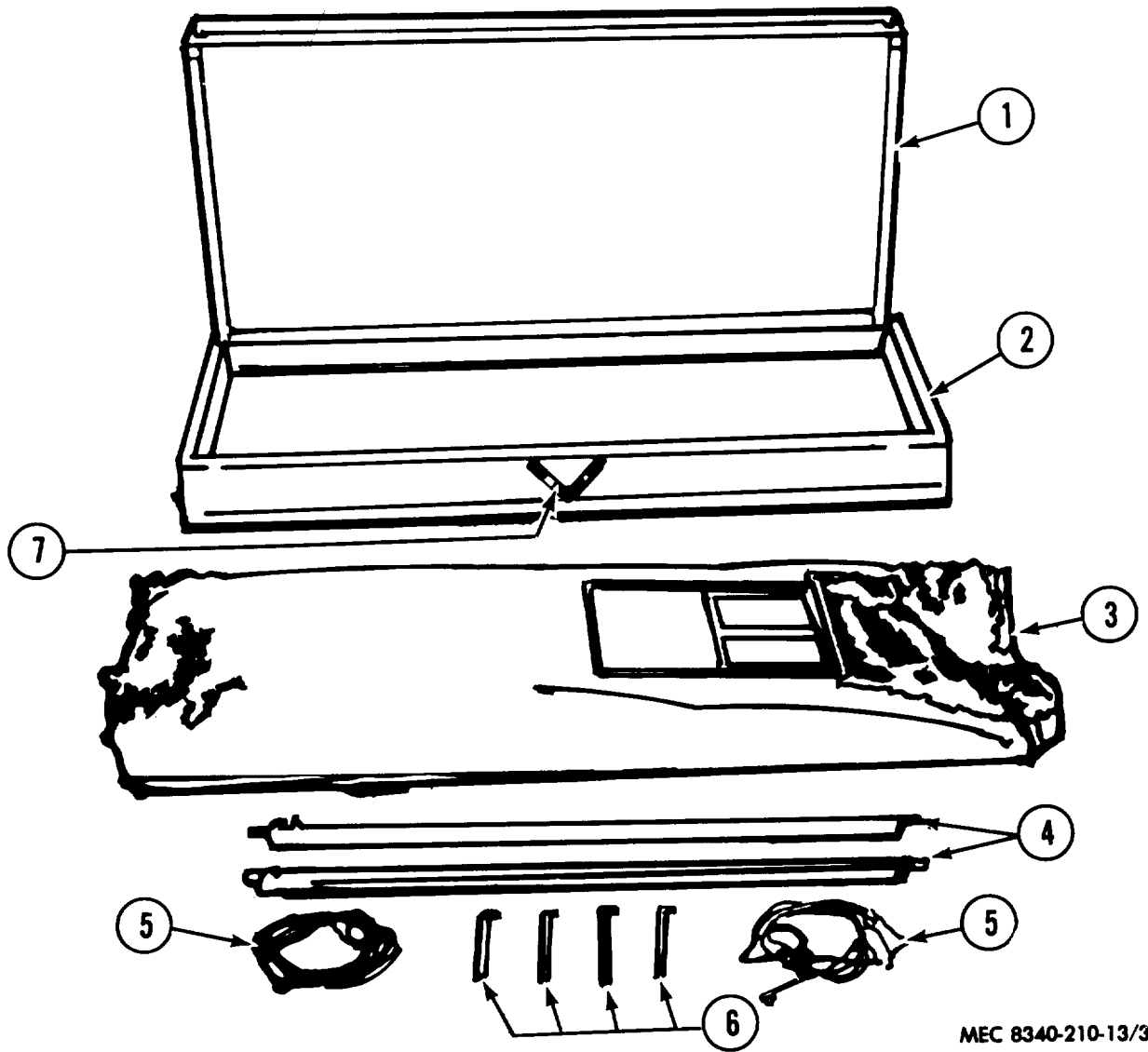

- | | | | | | |
|---|------------------|---|----------------------------|---|------------------|
| 1 | Floor unit, tent | 3 | Blanket assembly, tent end | 5 | Lines, tent |
| 2 | Floor unit, tent | 4 | Purlins, end | 6 | Pins, tent |
| | | | | 7 | Key, socket head |

Figure 3. End section packing crate and components.

changeable. For the contents of these crates see table I. Uncrate the four remaining crates as follows:

- (a) Remove the metal banding and the blocking from the packing case.
- (b) Remove the key (8, fig. 2 and 7, fig. 3) from the side of the floor unit (2, fig. 2 and 2, fig. 3).
- (c) Insert the key in the keyhole at one corner of the packing crate. Turn the key to unlock the floor

units. Unlock the roto locks at the remaining three corners.

- (d) Remove floor unit (1, fig. 2 and 1, fig. 3) from floor unit (2, fig. 2 and 2, fig. 3) and remove the contents of the crate.

- (6) Remove the crating material from each roof arch.

b. Inspecting. Perform the daily preventive maintenance services (para 20).

Note. If the tent is not to be erected at this time, crate it in accordance with instructions in paragraph 14.

Section II. USE UNDER USUAL CONDITIONS

10. General

This section furnishes the erection crew with the necessary illustrations and instructions for preparing the site and erecting and striking the tent. After the erection site has been prepared, the average erection time for an eight-man crew is 49 minutes.

11. Site Selection and Preparation

a. Site Selection.

- (1) Locate the tent site in a location which is level and firm as possible.
- (2) When possible, locate the site in an area with maximum natural cover.

b. Preparation of Site.

- (1) Mark off an area 16 feet 3 inches long and 16 feet 9 inches wide.
- (2) Use the proper tools to make the tent site as level as possible. Use maximum consideration for drainage.
- (3) Move the tent to the site, and place each tent packing crate in a convenient location around the site.

12. Erecting the Tent

Note. Perform the daily preventive maintenance services para 20) while removing the components from the packing crates.

a. Tent Floor and Frame.

- (1) Remove the socket head key from the side of any of the floor units.

- (2) Insert the key in the keyhole at one corner of each packing crate, and unlock the packing crates by turning the socket head key.

- (3) Unlock the remaining corners of the packing crate, and remove the top floor unit from the bottom floor unit.

- (4) Open the remaining packing crates by following the procedures in (1) through (3) above.

- (5) Remove the floor runners (4, fig. 2) from the floor unit (2), and place them on the tent site as shown in figure 4.

- (6) Starting at one end of the tent site, place two floor units end to end on the floor runners, and hook them together as shown in A, figure 4.

- (7) Place two remaining floor units removed from the top of the packing crates on the tent site next to the floor units already placed on the site. Hook the four floor units together as shown in B, figure 4.

- (8) Remove the tent components from the four packing crates, and place them on the four floor units which have been placed on the tent site.

- (9) Place two of the four remaining floor units on the tent site, and hook them as shown in B, figure 4.

- (10) Place the final two floor units on the tent site, and hook them on the inside

as shown in B, figure 4 and as shown in A, figure 4.

Note. Be certain the outside edges of the floor units are centered on the outside floor runners.

- (11) Unfold each arch, and install the pin in the connector leaf at each hinged joint.
- (12) Place an arch upright over the tent floor at the outside edge of the floor units. Lower the arch until the inside end of the arch clip, located on each end of the arch, is under the wing nuts, located on each floor unit. Tighten the wing nuts securely.

- (13) Place an arch upright over the tent floor. Lower the arch until the arch clip, located on each end of the arch, is under the wing nuts located on each floor unit.
- (14) Install the nine arch purlins between the two arches.
- (15) Install the next two arches on the tent floor, following the procedure in (13) above. Install the nine arch purlins between the arches.
- (16) Install the remaining arch on the opposite

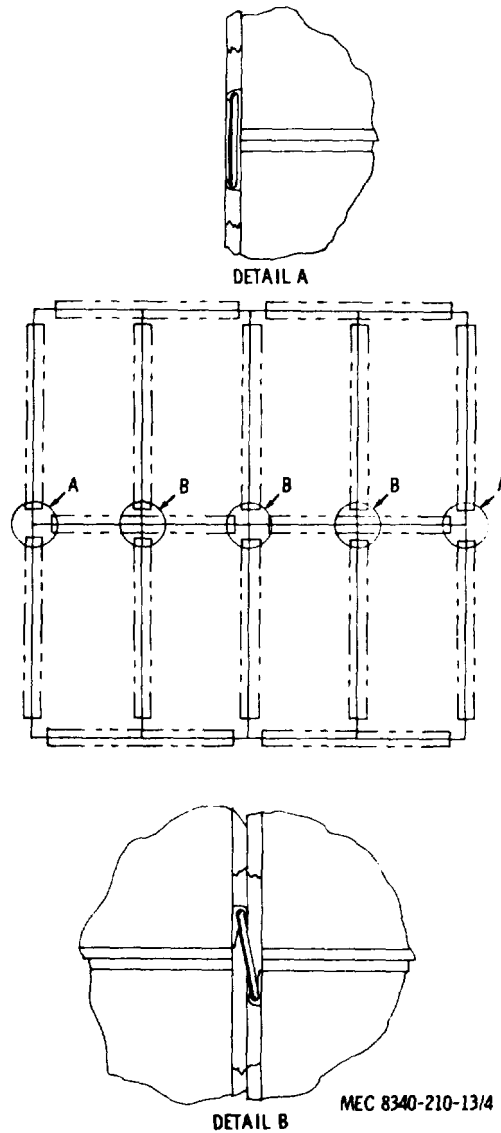

Figure 4. Floor units positioned on tent site.

end of the tent floor, following procedure in (13) above. Install the nine arch purlins between the arches.

- (17) Stake the footstop which is located on each end of each arch to the ground with a tent pin.

b. *Tent Body.*

- (1) Place an end blanket assembly on one end of the tent floor with the olive drab side upward.
- (2) Raise the end blanket assembly into position against the arch at the end of the tent floor. Be certain the lugs, located on the bottom of the door frame, are in their slots on the floor units. Slide the adjustable door frame under the wing nuts, located on the

inside of the arch. Tighten all wing nuts securely.

- (3) Pull the end of the end blanket securing line over the arch ferrule, and tie it securely. Pull the opposite end of the end blanket securing line until the end blanket assembly is secured around the arch, and tie it to the arch ferrule on the opposite end of the arch.
- (4) Fold the bottom flap of the end blanket assembly to the inside of the tent on the tent floor.
- (5) Insert the 12 buckles, located along the bottom of the end blanket assembly,

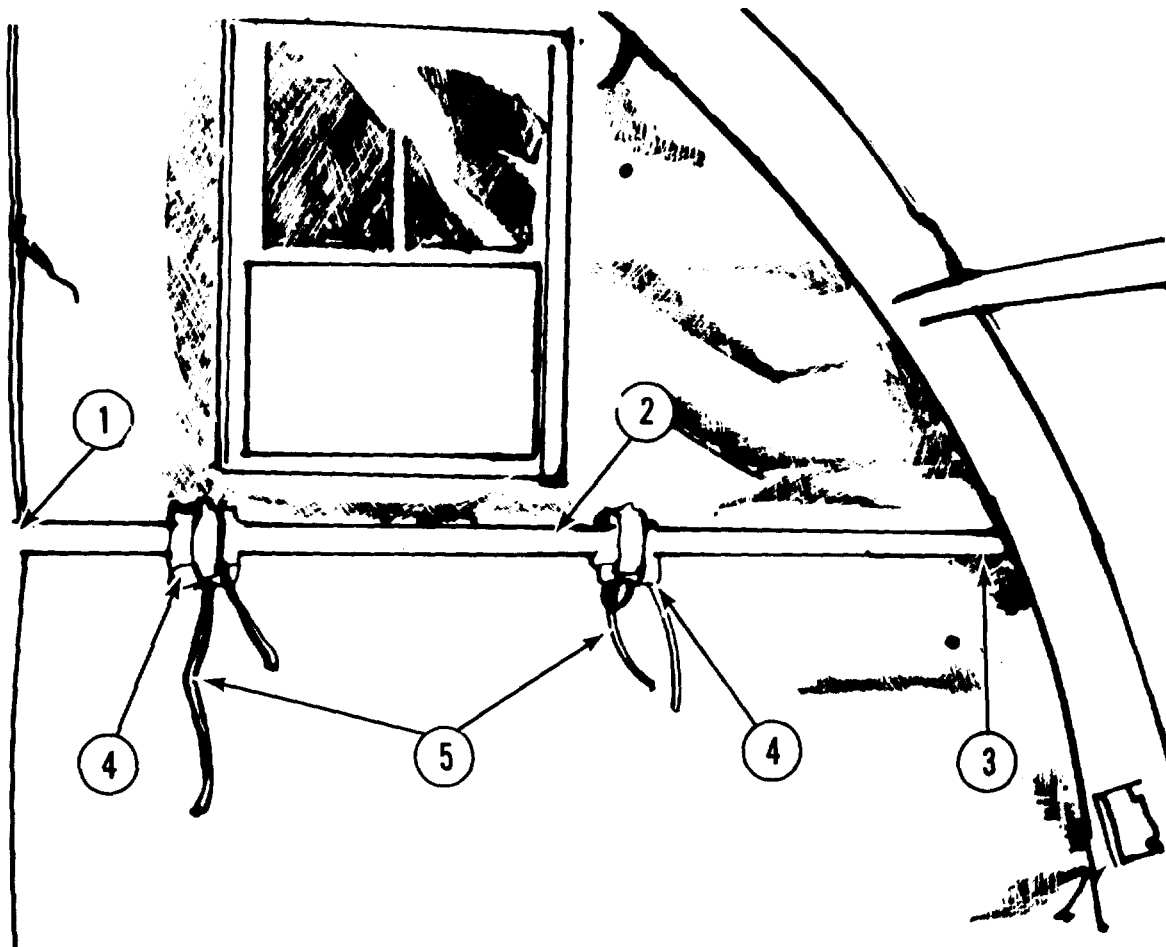

- | | | | |
|---|-----------------------|---|-----------------|
| 1 | Connector, adjustable | 4 | Lug |
| 2 | Purlin, end | 5 | Lines, securing |
| 3 | Connector, fixed | | |

Figure 5. End purlin installed on tent.

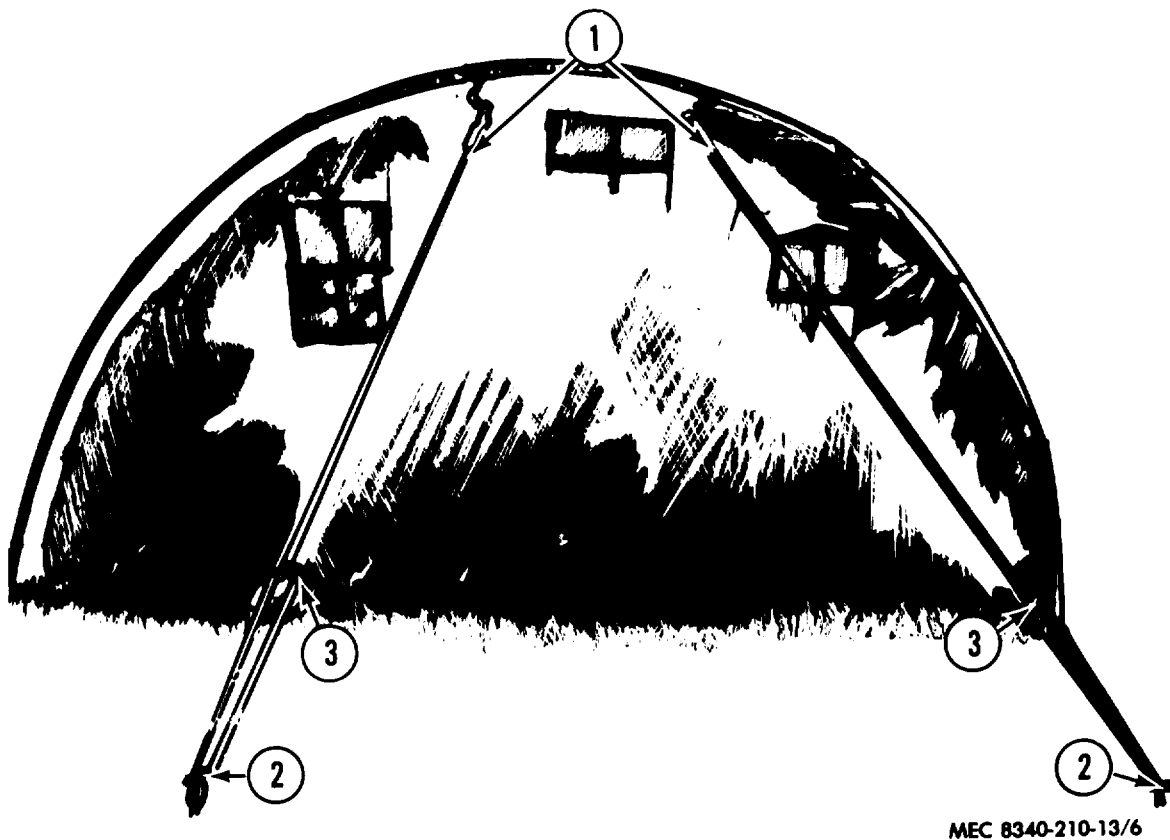

1 Lines, tent 2 Pins, tent 3 Slips, tent line

Figure 6. Rear outside view of erected tent..

into the matching holes in the floor units, and tighten the tie down chapes securely.

- (6) Place an end purlin (2, fig. 5) on one side of the door frame, and insert the connector (3) under the wing nut, located on the arch. Insert the connector (1) under the wing nut, located on the door frame, and tighten the wing nuts securely.
- (7) Secure the lugs (4) around the end purlin with the lines (5).
- (8) Install the remaining end purlin on the opposite side of the door frame, following the procedures in (6) and (7) above.
- (9) Using two tent pins, anchor the door frame footsteps to the ground.

- (10) Drive the two tent pins (2, fig. 6) into the ground. Unfold the tent lines (1), and hook them over the tent pins. Tighten the tent lines until all slack is removed.
- (11) Install the remaining end blanket assembly on the opposite end of the tent floor, following the procedures in (1) through (10) above.
- (12) Place a folded roof blanket assembly on the top arch purlin between two arches at one end of the tent, and secure the lugs around the purlin with the lines. Unfold the roof blanket assembly to each side of the tent.
- (13) Pull the edge of the roof blanket assembly over the arch and the end blanket securing line to the outside

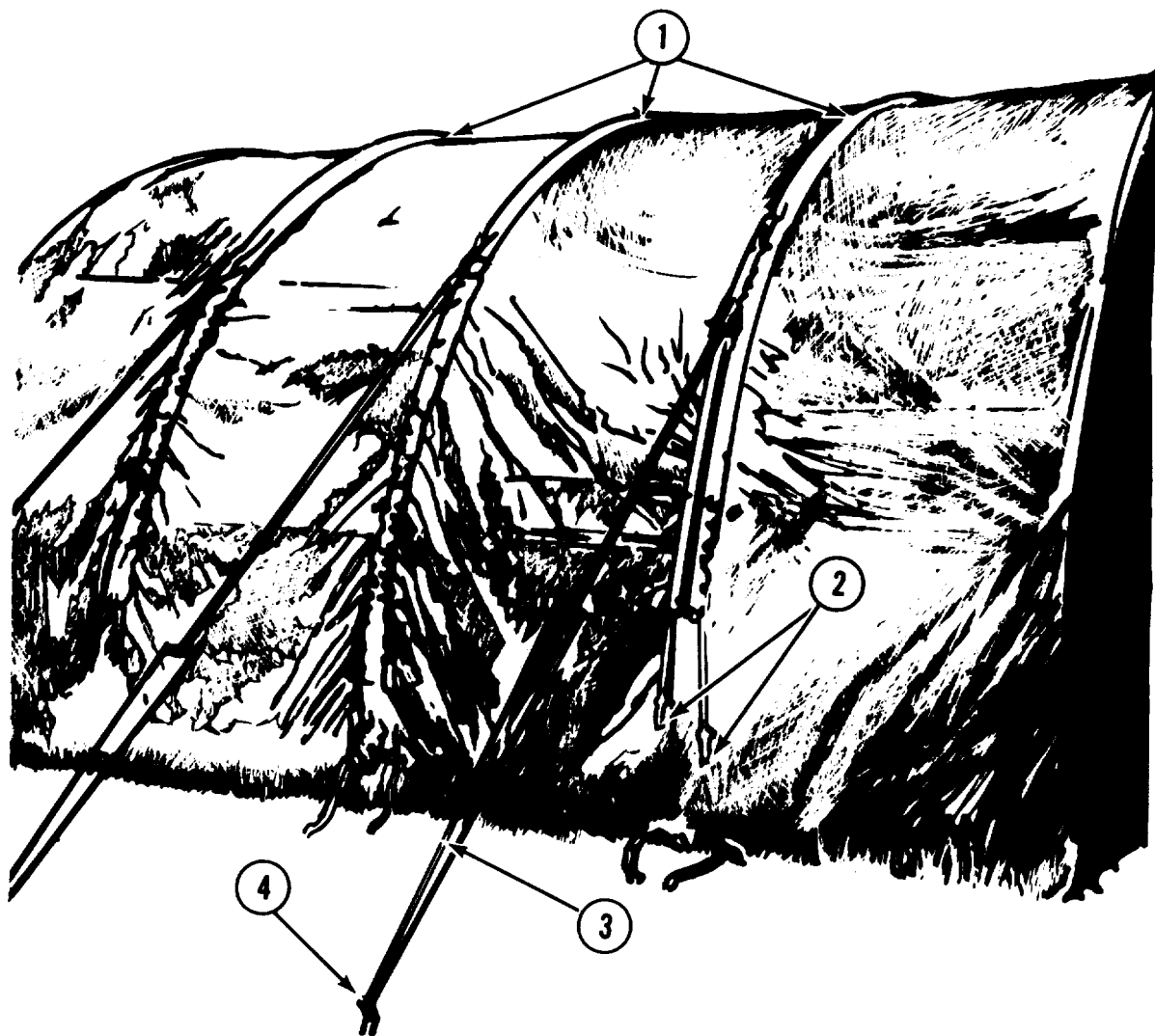

- | | | | |
|---|--------------------|---|----------------|
| 1 | Guyband assemblies | 3 | Line, tent guy |
| 2 | Straps | 4 | Pin, tent |

Figure 7. Guyband assemblies installed on tent.

- end of the arch ferrule. Pull the opposite end of the blanket securing line until the roof blanket assembly is taut over the arch. Tie the blanket line securely to the outside end of the arch ferrule on the opposite end of the arch.
- (14) Pull the opposite edge of the roof blanket assembly over the next arch, and tighten the blanket securing line

until the roof blanket assembly is taut. Tie the two ends of the blanket securing line around the opposite arch ferrules at the bottom of the arch.

- (15) Attach the remaining roof blanket assemblies to the tent frame, following the procedures in (12) through (14) above.
- (16) Fold the flaps at the bottom of the

roof blanket assemblies to the inside of the tent.

- (17) Insert the tie down chape buckles, located along the bottom edge of each blanket assembly, into the matching holes in the floor units. Tighten the tie down chapes until the roof blanket assemblies are snug against the floor units.
- (18) Unfold three guyband assemblies (1, fig. 7), and place them over the tent at the three intermediate arches. Drive three tent pins (4) into the ground on the left and right sides of the tent.
- (19) Place the two buckle hooks on each end of each strap (2) into the matching holes in the floor units, and tighten the straps until the guyband assemblies are secure.
- (20) Hook the three tent guy lines (3) on the left and right sides of the tent over the tent pins, and tighten them securely.

c. *Vestibule.*

- (1) Place the vestibule floor on the tent site, and align it with the tent door.
- (2) Loosen the wing nuts (2, fig. 8). Move the side panel assembly into position, hooking the steel angle, located on the side panel assembly, on the tent door frame. Tighten the wing nuts securely.
- (3) Loosen the wing nuts (1, fig. 8). Move the panel and door assembly into position, hooking the steel angle on the panel and door assembly on the tent door frame. Tighten the wing nuts securely.
- (4) Install the end purlin in the clips on the side panel assembly and the panel and door assembly.
- (5) Place the tie angle behind the wing nuts, and tighten the wing nuts securely.
- (6) Slide the gussets behind the wing nuts, and tighten the wing nuts securely. Secure the end cover (4, fig. 9) to the end purlin (3) with the line (2).

- (7) Install the top purlin (1) in the matching clips on the vestibule and tent.
- (8) Hook the 19 buckles, located on the end cover, into their matching holes in the vestibule, and tighten the 19 chapes securely.
- (9) Place the top cover in place over the vestibule, and tie one end of each securing line to the matching cleats. Pull the opposite end of each securing line tight, and tie it to the matching cleat on the side panel assembly.
- (10) Hook the top cover eight buckles into their matching holes in the vestibule, and tighten the eight chapes securely.

d. *Electrical Connector-Switch.*

- (1) Place the electrical connector-switch on the tent floor.
- (2) Loosen the proper wing nut, located on the tent door frame and place the switch box behind it. Tighten the wing nut securely.
- (3) Loosen the wing nut on the arch, and hook the cord clip behind it. Tighten the wing nut securely.
- (4) Extend the cord along the roof, and clip the cord hangers and the outlet hangers at desirable locations on the arch purlins.
- (5) Screw the lamps into the outlet sockets.
- (6) Have the electrical connector-switch connected to a suitable power source after (1) through (5) above have been completed.

13. Striking the Tent

a. *Electrical Connector-Switch.*

Warning: Disconnect power cable from power source.

- (1) Loosen the wing nut, and remove the switch box from the door frame.
- (2) Loosen the wing nut, and remove the cord clip from the arch.
- (3) Remove the cord hangers and the outlet hangers from the arch purlins, and

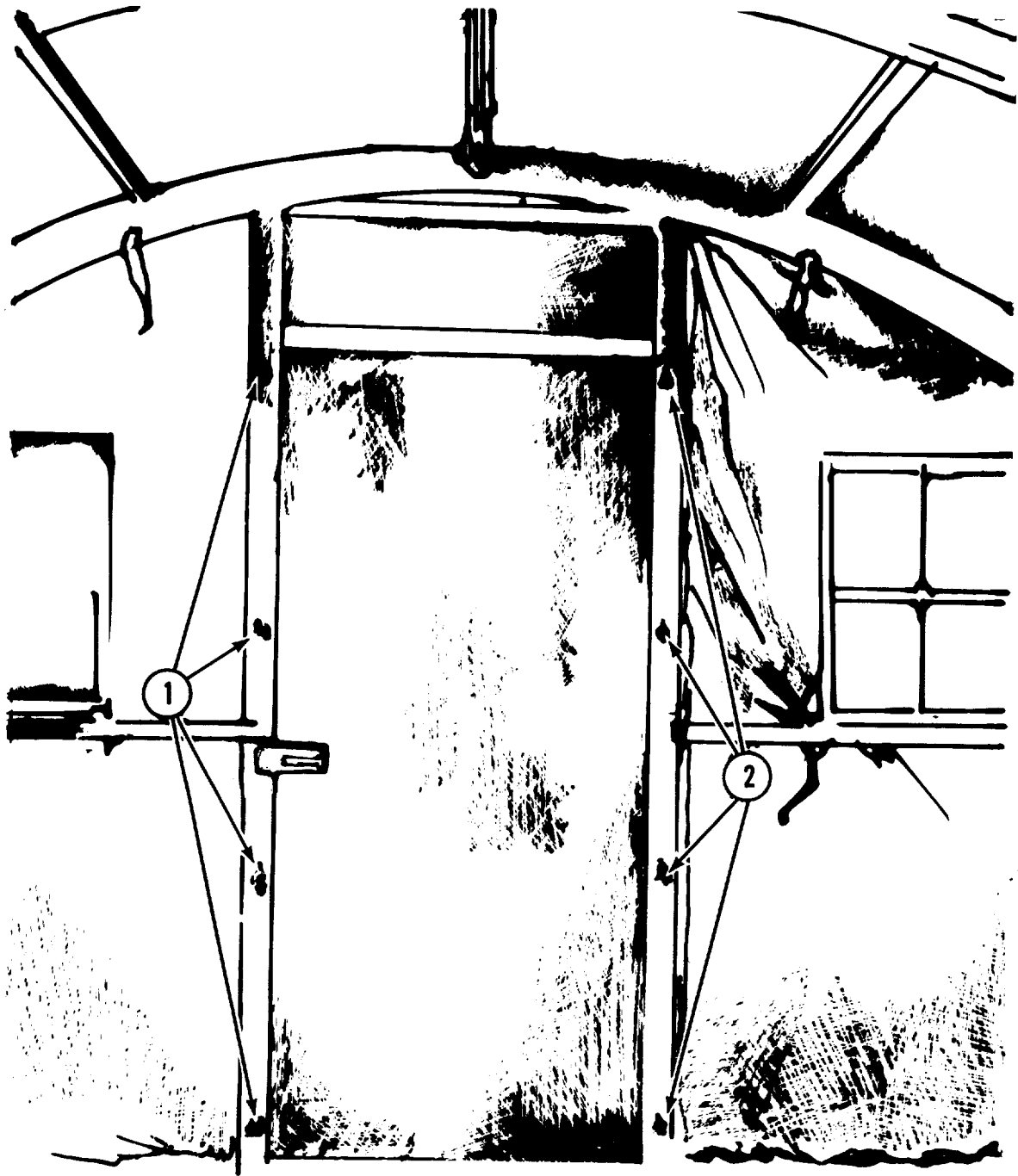

1 Nuts, wing

2 Nuts, wing

Figure 8. Tent door, inside view.

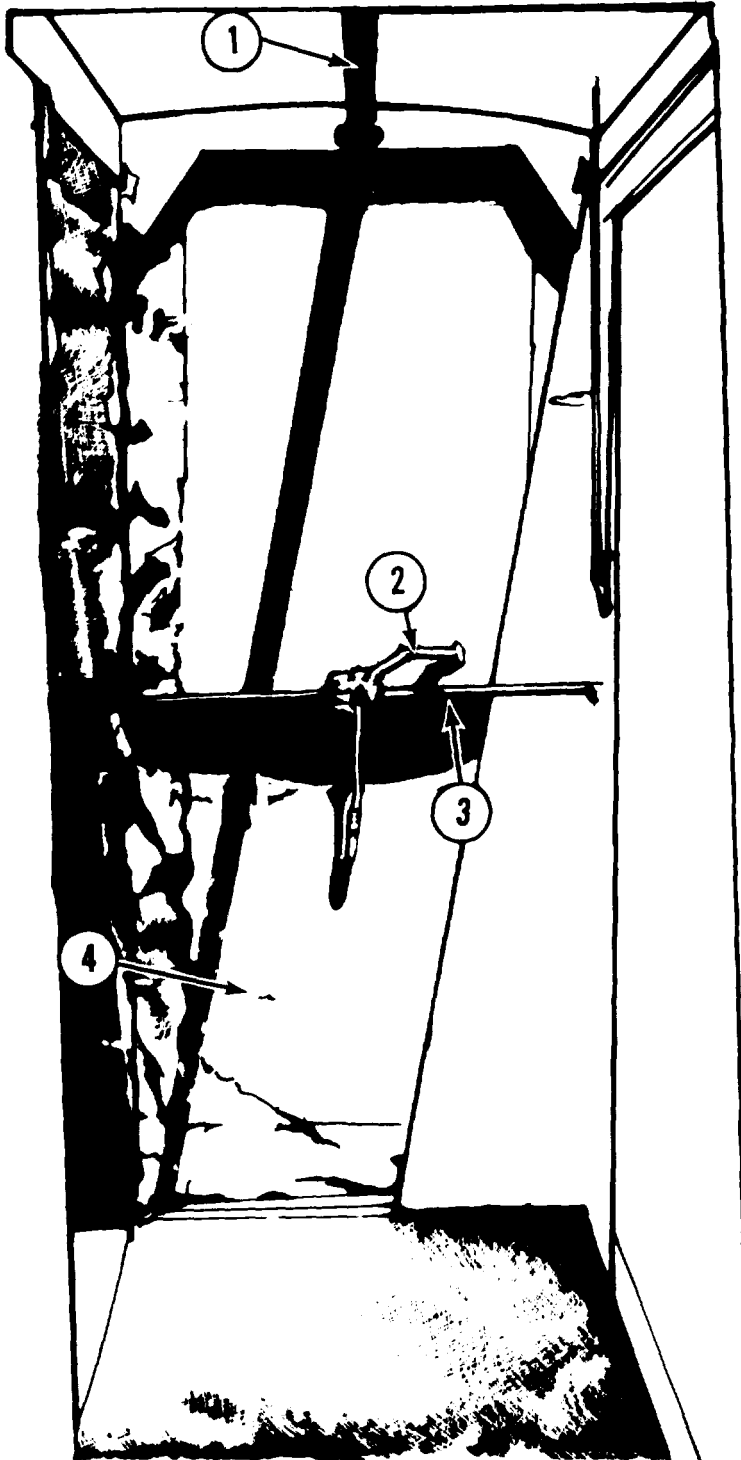

MEC 8340-210-13/9

- | | | | |
|---|------------------------|---|------------------------|
| 1 | Purlin, top, vestibule | 3 | Purlin, end, vestibule |
| 2 | Line, tent | 4 | Cover, end, vestibule |

Figure 9. Tent vestibule (inside view).

remove the connector-switch from the tent.

b. Vestibule.

Note. Use the proper blocking to stack the vestibule components.

- (1) Untie each end of each top cover securing line, and remove them from the cleats.
- (2) Loosen the eight top cover chapes, and unhook the eight top cover buckles. Remove the top cover from the vestibule.
- (3) Untie the line (2, fig. 9), and remove the end cover (4) from the end purlin (3). Remove the end purlin from the vestibule.
- (4) Loosen the wing nuts, and remove the tie angle from the vestibule floor.
- (5) Loosen the 19 end cover chapes, and unhook the 19 end cover buckles.
- (6) Loosen the four wing nuts securing the end cover gussets and remove the end cover from the vestibule.
- (7) Loosen the wing nuts (1, fig. 8), and remove the panel and door assembly from the tent.
- (8) Loosen the wing nuts (2), and remove the side panel assembly from the tent.
- (9) Move the vestibule floor away from the tent.

c. Tent Body.

Note. When the tent body components are removed, place them neatly on the rear of the tent floor.

- (1) Loosen the tent lines (1, fig. 6), and remove them from the tent pins. Fold and tie the lines neatly.
- (2) Remove the two tent pins from the ground.
- (3) Repeat the procedures in (1) and (2) above for removal of the tent lines located on the opposite end of the tent.
- (4) Loosen the three tent lines (3, fig. 7), and remove them from the tent pins. Fold and tie the lines neatly.
- (5) Remove the tent pins from the ground.

- (6) Repeat the procedures in (4) and (5) above for removal of the tent lines on the opposite side of the tent.
- (7) Loosen the two straps (2, fig. 7) on each end of each guyband assembly (1), and remove the buckles from the tent floor.
- (8) Remove the guyband assemblies from the tent, and fold them neatly.
- (9) Untie and remove the roof blanket assembly securing line from the collar on each end of each arch.
- (10) Loosen the chapes, located along the bottom of the roof blanket assembly, and remove the buckles from the tent floor.
- (11) Untie the securing lines from the arch purlins, and remove the roof blanket assemblies from the tent. Fold each roof blanket assembly neatly to fit in the packing crate.
- (12) Untie and remove the end blanket assembly securing line from the arch ferrule at each end of the arch.
- (13) Loosen the end blanket assembly chapes, and remove the buckles from the tent floor.
- (14) Remove the tent pins from the door frame footstops.
- (15) Unbuckle the tie down chapes from the arch.
- (16) Untie the lines (5, fig. 5), and remove the lugs (4) from the end purlins (2).
- (17) Loosen the wing nuts, and slide the connectors (1 and 3) from the bolts.
- (18) Repeat procedures in (16) and (17) above for removal of the opposite side of the end blanket assembly.
- (19) Lean the end blanket assembly to the inside of the tent, and lift it up to clear the tent floor, and place it on the tent floor with the outside down.
- (20) Fold the end blanket assembly neatly to fit the packing crate.
- (21) Repeat the procedures in (12) through (20) above for the removal of the opposite end blanket assembly.

d. Tent Frame.

- (1) Remove the tent pins from the arch footsteps at each end of each arch.
 - (2) Starting at one end of the tent frame, remove the arch purlins from between the first two arches.
 - (3) Loosen the wing nuts at each eyed of the first arch, and remove the arch from the tent floor.
 - (4) Remove the cotter pin from the straight pill at each arch joint, and remove the straight pin from each connector leaf. Fold the arch.
 - (5) Repeat the procedures in (3) and (4) above for removal of the remaining arches.
 - (6) Remove the tent hook (A, fig. 4), and pull the two floor units away from the remaining floor units. Remove the tent hook from the opposite side of the two floor units.
 - (7) Unhook the remaining tent hooks, and remove the remaining floor units from the floor runners.
 - (8) Remove the floor runners from the tent site.
 - (9) Crate the tent components, following the procedures in paragraph 14.
- (4) Use the locking tool (7) to lock the two floor units together at each corner.
 - (5) Repeat the procedures in (1) through (4) above to crate the remaining end blanket assembly.
 - (6) Use the floor unit (2, fig. 2) as a crate bottom. Place 2 roof blanket assemblies (3), 8 tent pins (6), 18 arch purlins (7), 2 guyband assemblies (5), and 8 floor runners (4) into the floor unit.
 - (7) Place the floor unit (1) on the floor unit (2), and use the locking tool (8) to lock the two floor units together at each corner.
 - (8) Crate the remaining 2 roof blanket assemblies, 18 arch purlins, 8 floor runners, 2 guyband assemblies, and 8 tent pins, following the procedures in (6) and (7) above.
- b. Tent Arches. Use the proper banding material to band each folded arch at the ends and in the middle to prevent it from unfolding during transit.
 - c. *Vestibule.*
 - (1) Use the proper blocking, and place the panel and door assembly on the side panel assembly.
 - (2) Place the end cover and top cover on the panel and door assembly.
 - (2) Place the end cover and top cover on the panel and door assembly.
 - (3) Place the tie angle, electrical connector-switch, vestibule end purlin, and the vestibule top purlin on the top cover.
 - (4) Place the vestibule floor over the end cover.
 - (5) Use the proper banding material to band the vestibule components together.

14. Crating the Tent

a. *Tent Body and Floor.*

- (1) Use the floor unit (2, fig. 3) as a crate bottom, and place one end blanket assembly (3) into the floor unit with the window assembly facing up.
- (2) Place the two end purlins (4) and the four tent pins (6) on top of the end blanket assembly.
- (3) Place a floor unit (1) on top of the floor unit (2).

Section III. USE UNDER UNUSUAL CONDITIONS

15. General

This section contains the special operating instructions in addition to those contained in paragraphs 10 through 14, which are necessary for the proper functioning of the tent in extreme cold and wet climates.

16. Use in Extreme Cold and Wet Climate

a. *Extreme(Cold.*

- (1) When selecting a tent site on snow-covered ground, prod the surface with a sharp pointed pole to locate any concealed crevices. If the tent site

must be located where there are crevices, mark their locations to avoid accidents.

- (2) When snow is present on the tent site, pack it down level by stamping on it.
- (3) Use a soft brush or broom to brush the snow from the tent roof, frequently, to avoid undue weight being placed on the tent frame.

b. Wet Climate.

- (1) Always keep tent lines loose enough to prevent the tent pins from being pulled out of the ground when the lines shrink from dampness.
- (2) Slope the tent site down from each edge of the tent floor and the vestibule floor.
- (3) Dry the tent components before crating them.

CHAPTER 3

USER AND ORGANIZATIONAL MAINTENANCE INSTRUCTIONS

Section I. TOOLS AND EQUIPMENT

personnel are listed and illustrated in TM 108340-210-23P.

17. Repair Parts and Equipment

a. The repair parts and equipment supplied with this tent are listed on the basic issue items list and illustrated in appendix II.

b. The repair parts authorized for use by organizational and direct support maintenance

18. Tools

a. The tools supplied with the tent are listed on the basic issue items list and illustrated in appendix II.

b. Common tools authorized by unit TO&E are appropriate for erection and disassembly of the tent.

Section II. PREVENTIVE MAINTENANCE SERVICES UNDER USUAL AND UNUSUAL CONDITIONS

19. General

To insure that the tent is ready for use at all times, it must be inspected systematically so that defects may be discovered and corrected before they result in serious damage. The necessary preventive maintenance services to be performed are listed and described in paragraphs 20 and 21. The item numbers indicate the sequence of minimum inspection requirements. Defects discovered during use of the tent shall be noted for future correction, to be made as soon as possible. All deficiencies and shortcomings, together with the corrective action taken, will be recorded on DA Form 2404 (Equipment Inspection and Maintenance Worksheet) at the earliest possible opportunity.

20. Daily Preventive Maintenance Services

This paragraph contains an illustrated tabulated listing of preventive maintenance services which must be performed by the user. The item numbers are listed consecutively, and indicate the sequence of minimum requirements. Refer to figure 10 for the daily preventive maintenance services.

21. Quarterly Preventive Maintenance Services

The daily preventive maintenance services (fig. 10) will be performed at the quarterly interval by organizational maintenance personnel.

PREVENTIVE MAINTENANCE SERVICES

DAILY

TM 10-8340-210-13

TENT, FRAME-TYPE,
SECTIONAL, M-1948

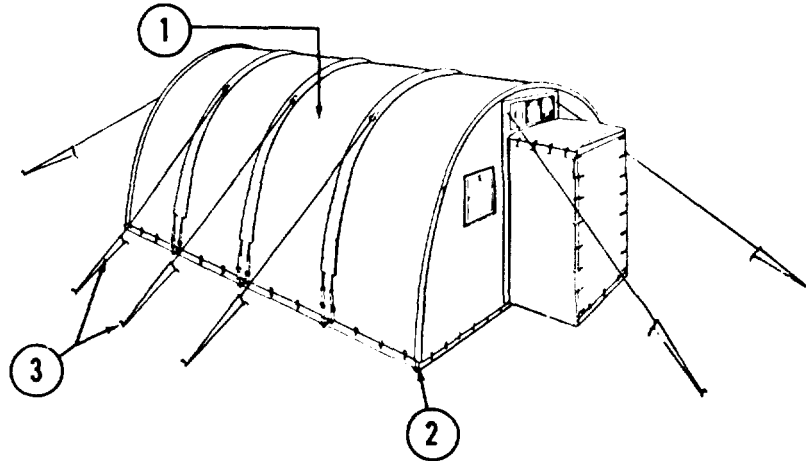

LUBRICATE IN ACCORDANCE WITH CURRENT LUBRICATION ORDER

ITEM

PAR REF

1	<u>TENT BODY</u> . Check for torn, cut, or dirty fabric. Check for cracked, deteriorated, or broken door and window parts. Check for bent, broken, deteriorated or missing hardware. Check for frayed, cut, or dirty webbing, tape, and rope parts.	22, 23, 24, 25,
2	<u>TENT SUPPORT COMPONENTS</u> . Check for cracked, broken, deteriorated, missing or bent metal and wooden parts.	26, 27, 28, 29,
3	<u>TENT ANCHORING COMPONENTS</u> . Check for torn, cut, or dirty fabric parts. Check for bent, broken, missing or corroded metal parts. Check for cut, frayed, deteriorated, or dirty webbing, tape, and rope parts.	31,36, 37,
4	NOTE: <u>TENT ACCESSORIES</u> . Check for bent, broken, missing or corroded metal parts. Inspect the electrical cord for cut, broken, deteriorated or dirty insulation.	35, 36, 37,

MEC 8340-210-13/10

Figure 10. Daily preventive maintenance services.

Section III. TENT BODY

22. General

The tent body is made up of two end blanket assemblies and four roof blanket assemblies. When the tent is erected, the tent body fits over the tent frame to form the tent walls and the tent roof.

23. Maintenance of the Tent Body

a. *Inspect.* For inspection, refer to item no. 11, figure 10.

b. *Service.*

- (1) Clean the fabric of the end blanket assemblies, roof blanket assemblies, vestibule end cover, and vestibule top cover by-
 - (a) Removing loose dirt with a soft-bristled brush; and
 - (b) Removing stains and dirt with a mild soap and water solution and a soft-bristled brush.
- (2) Clean the wooden and metal parts of the end blanket assemblies by-
 - (a) Removing dirt or corrosion with a soft-bristled brush and a mild soap and water solution; and
 - (b) Removing loose dirt with a cloth dampened with clean water.

c. *Repair.*

- (1) *Cement patch.* Apply a cement patch to any fabric hole or rip, not greater than 4 3/4 inches in diameter or length, by following the proper procedures in TM 10-633.

Note. If the damaged area supports a grommet, a cement patch cannot be used.

(2) *Paint.*

- (a) Remove any damaged paint from the wooden or metal parts, and clean the area (b above).
- (b) Apply a coat of coating primer (FSN 8010-161-7425) to clean surface and allow it to dry to the touch.
- (c) Apply a coat of enamel (FSN 8010-297-2124) over the primed area.

24. Replacement of the End Blanket Assemblies and Parts

a. *Guy Line Eye Bolts.*

- (1) Remove the end guy line snap hook from the guy line eye bolt.
- (2) Remove the wing nut and flat washer from the guy line eye bolt, and remove the eye bolt from the door frame and door assembly.
- (3) Install a serviceable guy line eye bolt on the end blanket assembly, reversing the procedures in (1) and (2) above.
- (4) Follow the procedures in (1) through (3) above for replacement of the remaining guy line bolt.

b. *Purlin Clips.*

- (1) Remove the two wood screws from the purlin clip, and remove the purlin clip from the outside of the door frame and door assembly.
- (2) Install a serviceable purlin clip on the door frame and door assembly, reversing the procedure in (1) above.
- (3) Replace the purlin clip on the remaining door frame and door assembly, following the procedures in (1) and (2) above.

c. *Door Frame Adjustable Connectors.*

- (1) Loosen the wing nut on the arch bolt, and remove the wing nuts and the flat washers from the door frame bolt and the tent line eye bolt.
- (2) Remove the door frame adjustable connector from the door frame and door assembly.
- (3) Install a serviceable door frame adjustable connector on the door frame and door assembly, reversing the procedures in (1) and (2) above.

Note. If an electrical cord clip was attached on any one of the bolts, install it at the same location before tightening the wing nut.

- (4) Replace the remaining door frame adjustable connectors, following the procedures in (1) through (3) above.

- d. *Stovepipe Opening Covers.*
 - (1) Remove the four tapping screws from the stovepipe opening cover, and remove it from the stovepipe opening plate.
 - (2) Install a serviceable stovepipe opening cover, reversing the procedures in (1) above.
 - (3) Replace the remaining stovepipe opening cover, following the procedures in (1) and (2) above.
- e. *Stovepipe Opening Plates.*
 - (1) Remove the four tapping screws from the stovepipe opening cover, and remove it from the stovepipe opening plate.
 - (2) Remove the nails from the stovepipe opening plate, and remove it from the door frame and door assembly.
 - (3) Install a serviceable stovepipe opening plate and a serviceable stovepipe opening cover, reversing the procedures in (1) and (2) above.
 - (4) Remove the remaining stovepipe opening plate, following the procedures in (1) through (3) above.
- f. *Transom Keepers, Eye Screw, and Latching Straps.*
 - (1) Remove the two wood screws securing the transom keeper to the door frame and frame assembly, and remove the transom.
 - (2) Install a serviceable transom keeper on the door frame and door assembly, reversing the procedures in (1) above.
 - (3) Replace the remaining transom keeper, following the procedures in (1) and (2) above.
 - (4) Remove the eye screw from the door frame and door assembly, and install a serviceable one.
 - (5) Replace the remaining eye screw, following the procedure in (4) above.
 - (6) Remove the two wood screws securing the latching strap to the door frame and door assembly, and remove the latching strap.
 - (7) Install a serviceable latching strap on the door frame and door assembly, reversing the procedures in (6) above.
 - (8) Replace the remaining latching strap, following the procedures in (6) and (7) above.
- g. *Transom.*
 - (1) Remove the four wood screws from each transom hinge, and remove the two hinges from the transom and the door frame and door assembly.
 - (2) Remove the transom from the door frame and door assembly.
- h. *Tent Door Latch Keepers.*
 - (1) Remove the wood screws from the tent door latch keeper, and remove it from the door frame and door assembly.
 - (2) Install a serviceable tent door latch keeper, reversing the procedure in (1) above.
 - (3) Replace the remaining tent door latch keeper, following the procedures in (1) and (2) above.
- i. *Tent Door Latches.*
 - (1) Remove the four screws that secure the outside handle to the tent door, and remove the outside handle from the tent door.
 - (2) Remove the screws that secure the tent door latch to the inside of the tent door, and remove the tent door latch from the tent door.
 - (3) Install a serviceable door latch, reversing the procedures in (1) and (2) above.
 - (4) Replace the remaining tent door latch, following the procedures in (1) and (2) above.
- j. *Tent Door Gaskets.*
 - (1) Tack the gasket to the plywood panels of the door, leaving a 1/2-inch loop at the bottom of the door.
 - (2) Replace the remaining tent door gasket, following the above procedure.
- k. *Tent Doors and Butt Hinges.*

- (1) Remove the six wood screws from each butt hinge, and remove the butt hinges from the door frame and door assembly.
- (2) Remove the tent door from the door frame.
- (3) Install a serviceable tent door, with butt hinges, reversing the procedures in (1) and (2) above.
- (4) Replace the remaining tent door and butt hinge, following the procedures in (1) through (3) above.

l. Blanket Securing Lines.

- (1) Untie the overhand knot in the blanket securing line (4, fig. 5), and remove it from the securing lug and the end purlin.
- (2) Install a serviceable blanket securing line in the securing lug, and tie an overhand knot in each running end.
- (3) Tie the blanket securing line around the end purlin.
- (4) Replace the remaining blanket securing line following the procedures in (1) through (3) above.

m. Window, Sash Hooks and Eyes.

- (1) Unscrew and remove the window sash hook and eye from the window assembly.
- (2) Install a serviceable window sash hook and eye on the window assembly.
- (3) Replace the remaining window sash hooks and eyes, following the procedures in (1) and (2) above.

n. Chape End Clips.

- (1) Cut any frays from the cut end of the chape.
- (2) Place a new end clip on the chape, and flatten the end clip with a hammer.

Note. Be certain the end clip is mounted securely on the chape.

- (3) Replace the remaining chape clips by following the procedures in (1) and (2) above.

o. End Blanket Assemblies.

- (1) Remove an end blanket assembly, following the striking procedures in paragraph 13c.
- (2) Install a serviceable end blanket assembly, following the erection procedures in paragraph 12b.

25. Replacement of Vestibule Top Cover and Parts and Vestibule End Cover and Parts

a. End Cover Purlin Clip.

- (1) Remove the two wood screws from the end cover purlin clip, and remove it from the end cover.
- (2) Install a serviceable end cover purlin clip, reversing the procedures in (1) above.

b. Vestibule End Cover Securing Line.

- (1) Untie and remove the end cover securing line from the end purlin.
- (2) Untie the overhand knot, and remove the end cover securing line from the lug.
- (3) Install a serviceable end cover securing line in the lug, and tie an overhand knot in each running end.
- (4) Tie the end cover securing line around the end purlin.

c. End Cover Binding Strip

- (1) Remove the eight wood screws from the end cover binding strip, and remove it from the end cover retainer.
- (2) Install a serviceable end cover binding strip on the end cover retainer, reversing the procedure in (1) above.

d. Tie Down Chape End Clips.

- (1) Cut any frays from the cut end of the tie down chape.
- (2) Place a new end clip on the tie down chape, and flatten the end clip with a hammer.

Note. Be certain the end clip is mounted securely on the tie down chape.

- (3) Replace the remaining tie down chape end clips, following the procedures in (1) and (2) above.

- e. *Vestibule End Cover.*
 - (1) Remove the end cover from the vestibule, following the striking procedures in paragraph 13a.
 - (2) Install a serviceable end cover on the vestibule, following the erection procedures in paragraph 12c.
- f. *Top Cover Securing Line.*
 - (1) Untie and remove the top cover securing line from the top purlin.
 - (2) Untie the overhand knot from the top cover securing line, and remove it from the lug.

- (3) Install a serviceable top cover securing line in the lug, and tie an overhand knot in each running end.
- (4) Tie the top cover securing line around the top purlin.

g. *Vestibule Top Cover.*

- (1) Remove the top cover from the vestibule, following the proper procedures in paragraph 13a.
- (2) Install a serviceable top cover on the vestibule, following the proper procedures in paragraph 12c.

Section IV. TENT SUPPORT COMPONENTS

26. General

The tent support components are the tent floor, tent arches, door assembly, wall assembly, and their connecting parts. When the tent is erected, the tent support components form the framework and foundation of the tent body.

27. Maintenance of the Tent Support Components

a. *Inspect.* For inspection, refer to item no. 2, figure 10.

b. *Service.* Clean the wooden and metal parts of the tent support components by (1) Removing dirt or corrosion with a soft-bristled brush and a mild soap and water solution; and (2) Removing loose dirt with a cloth dampened with clean water.

c. *Repair.* Follow the instructions in paragraph 23c(2) for painting the metal and wooden parts of the tent support components.

28. Replacement of Arches and Parts

a. *Lacing Ferrule Collars.*

- (1) Remove the blanket securing lines from the lacing ferrule collar.
- (2) Remove the nut from the capscrew, and remove the capscrew from the flat washers, lacing ferrule collars, and the arch.

Note. When the capscrew is removed the flat washers and lacing ferrule collars will fall free of the arch.

- (3) Install a flat washer, lacing ferrule collar, and another flat washer on the capscrew.
- (4) Install the capscrew through the arch, and install a flat washer, lacing ferrule collar, another flat washer, and nut on the capscrew.
- (5) Tie the blanket securing lines around the lacing ferrule collars.
- (6) Replace the remaining lacing ferrule collars, following the procedures in (1) through (5) above.

b. *Leaf Connector Headed Pin, Chain, and Cotter Pins.*

- (1) Remove the cotter pin from the headed pin, and remove the headed pin from the leaf connectors.
- (2) Disconnect the headed pin from the chain, removing the cotter pin from the headed pin.
- (3) Remove the remaining cotter pin from the leaf connector and the chain.
- (4) Install a cotter pin in each end of a serviceable chain.
- (5) Drill a 3/16-inch hole in each end of the headed pin for installation of the cotter pins.

Note. Use the unserviceable headed pin to determine the location of the cotter pin holes.

- (6) Install one end of the chain to the headed pin with the cotter pin.
- (7) Install the remaining end of the chain to the leaf connector.
- (8) Install the headed pin in the leaf connectors, and install a cotter pin in the headed pin.
- (9) Replace the remaining leaf connector headed pins, chains, and cotter pins, following the procedures in (1) through (8) above.

c. Arch Bolts and Wing Nuts.

- (1) Remove the wing nut from the bolt on the arch, and remove the end purlin from the bolt. Remove the bolt from the arch.
- (2) Install a serviceable bolt in the arch and end purlin, and install the wing nut on the bolt.
- (3) Replace the remaining arch bolts and wing nuts, following the procedures in (1) and (2) above.

d. End Purlins.

- (1) Remove the two wing nuts from the bolts, and loosen the wing nut at the door frame. Remove the adjustable connector from the end purlins.
- (2) Remove the bolts from the end purlin.
- (3) Loosen the wing nut securing the fixed connector to the arch, and remove the end purlin from the arch.
- (4) Install a serviceable end purlin, reversing the procedures in (1) through (3) above.

e. Tent Arch Purlins.

- (1) Untie and remove the blanket securing line from the tent arch purlin.
- (2) Remove the tent arch from the arches.
- (3) Install a serviceable tent arch purlin on the arches, and tie the blanket securing line to the tent arch purlin.
- (4) Replace the remaining tent arch purlins, following the procedures in (1) through (3) above.

f. Arches.

- (1) Remove the arches, following the procedure in paragraph 13d.
- (2) Install serviceable arches by following the procedure in paragraph 12a.

29. Replacement of Tent Floor Units and Parts

a. T-Head Bolt and Wing Nut.

- (1) Support the arch and the floor unit with the proper blocking to permit access to the inside of the floor unit.
- (2) Remove the wing nut from the T-head bolt, and remove the bolt from the floor unit.
- (3) Install a serviceable T-head bolt in the floor unit.
- (4) Remove the blocking from the arch and floor unit, and place the arch clip on the T-head bolt.
- (5) Install the wing nut on the T-head bolt.
- (6) Replace the remaining T-head bolts and wing nuts by following the procedures in (1) through (5) above.

b. Tent Hooks and Chains.

- (1) Remove the tent hook from the locking socket, and remove the cotter pin from the tent hook.
- (2) Remove the cotter pin from the chain, and remove the chain from the floor unit.
- (3) Install a serviceable tent hook and chain on the floor unit, reversing the procedures in (1) and (2) above.
- (4) Replace the remaining tent hooks and chain, following the procedures in (1) through (3) above.

c. Locking Sockets.

- (1) Remove the tent hook from the locking socket.
- (2) Remove the three wood screws from the locking socket, and remove the locking socket from the floor unit.
- (3) Install a serviceable locking socket, reversing the procedures in (1) and (2) above.

- (4) Replace the remaining locking sockets, following the procedures in (1) through (3) above.

d. *Door Post Sockets.*

- (1) Support the door frame and door assembly, and remove the two wood screws from the door post socket. Remove the door post socket from the floor unit.
- (2) Install a serviceable door post socket on the floor unit, reversing the procedures in (1) above.
- (3) Replace the remaining door post sockets, following the procedures in (1) and (2) above.

e. *Floor Corner Supports.*

- (1) Remove the three wood screws from the floor corner support, and remove the floor corner support from the floor unit.
- (2) Install a serviceable floor corner support on the floor unit, reversing the procedure in (1) above.
- (3) Replace the remaining floor corner supports, following the procedures in (1) and (2) above.

f. *Tent Floor Runners and Floor Units.*

- (1) Strike the tent (para 13).
- (2) Erect the tent, using serviceable tent floor units and floor runners as required.

30. Replacement of Vestibule Parts

a. *Panel and Door Assembly.*

Note. Replace the panel and door assembly, following the proper procedures in paragraphs 12c and 13a.

- (1) *Rope Cleats.*
 - (a) Remove the securing line from the rope cleat.
 - (b) Remove the two wood screws from the rope cleat, and remove the rope cleat from the panel and door assembly.
 - (c) Install a serviceable rope cleat, reversing the procedures in (a) through (b) above.
 - (d) Replace the remaining rope cleat, following the procedures in (a) through (c) above.
- (2) *Door latch keeper.*

- (a) Remove the screws from the door latch keeper, and remove it from the panel and door assembly.

- (b) Install a serviceable door latch keeper, reversing the procedures in (a) above.

(3) *Vestibule door latch.*

- (a) Remove the four screws that secure the outside handle to the vestibule door, and remove the outside handle from the vestibule door.

- (b) Remove the screws that secure the inside of the vestibule door, and remove the vestibule door latch from the vestibule door.

- (c) Replace the vestibule door latch, following the procedures in (a) and (b) above.

(4) *Vestibule threshold.*

- (a) Remove the two nuts and flat washers from the two capscrews.

- (b) Remove the capscrews and vestibule threshold from the panel and door assembly.

- (c) Install a serviceable vestibule threshold, reversing the procedures in (a) and (b) above.

(5) *Butt hinges.*

- (a) Remove the six wood screws from each butt hinge, and remove the butt hinge from the panel and door assembly.

- (b) Install a serviceable butt hinge, reversing the procedure in (a) above.

- (c) Replace the remaining butt hinges, following the procedures in (a) and (b) above.

b. *Side Panel Assembly.*

Note. Replace the side panel assembly, following the proper procedures in paragraphs 12c and 13a.

- (1) *Rope cleats.* Follow the instructions in a(11) above to replace the rope cleats.

- (2) *Tie angle.*

- (a) Remove the two wing nuts from the two bolts, and remove the tie angle from the two bolts.
- (b) Remove the bolt from the side panel assembly and the bolt from the panel and door assembly.
- (c) Install a serviceable tie angle, reversing the procedures in (a) and (b) above.

c. *Top Purlin and End Purlin.*

(1) *Top purlin.*

- (a) Untie the securing line, and remove the lug from the top purlin.
- (b) Remove the top purlin from the vestibule end cover and tent door frame and door assembly.

- (c) Install a serviceable top purlin, reversing the procedures in (a) and (b) above.

(2) *End purlin.*

- (a) Untie the securing line, and remove the lug from the end purlin.
- (b) Remove the end purlin from side panel assembly and panel and door assembly.
- (c) Install a serviceable end purlin by reversing the procedures in (a) and (b) above.

d. *Vestibule Floor.* Replace the vestibule floor, following the proper procedures in paragraphs 12c and 13a.

Section V. TENT ANCHORING COMPONENTS

31. General

The tent anchoring components are the guyband assembly, tent guy lines, tent slips, and tent pins. When the tent is erected, the tent anchoring components hold the tent on the site.

32. Maintenance of the Tent Anchoring Components

a. *Inspect.* For inspection, refer to item no. 3, figure 10.

b. *Service.* Clean the fabric and metal parts of the tent anchoring components, following the instructions in paragraph 23b.

c. *Repair.* Repair the tent anchoring components, following the instructions in paragraph 23c.

33. Replacement of the Tent Pins, Tent Slips, and Tent Guy Lines

a. *Tent Slips.*

- (1) Untie the overhand knot in the tent guy line, and remove the tent guy line from the tent slip and tent pin.
- (2) Install a serviceable tent slip on the tent guy line, reversing the procedures in (1) above.
- (3) Replace the remaining tent slips, following the procedures in (1) through (3) above.

b. *Tent Pins.*

- (1) Loosen the tent guy line, and remove it from the tent pin.
- (2) Remove the tent pin from the ground.
- (3) Install a serviceable tent pin, reversing the procedures in (1) and (2) above.
- (4) Replace the remaining tent pins, following the procedures in (1) through (3) above.

c. *Tent Guy Lines.*

- (1) Loosen the tent guy line, and remove it from the tent pin and the tent slip.
- (2) Remove the opposite end of the tent guy line from the dee-ring on the guyband assembly.
- (3) Install a serviceable tent guy line on the tent, reversing the procedures in (1) and (2) above.
- (4) Replace the remaining tent guy lines, following the procedures in (1) through (3) above.

34. Replacement of Guyband Assemblies

a. *Guyband Assemblies.*

- (1) Loosen the four straps, and remove the four buckles from the floor units.
- (2) Loosen the two tent guy lines, and remove them from the tent pins.
- (3) Remove the guyband assembly from

the tent, and remove the tent guy lines from the guyband assembly.

- (4) Install a serviceable guyband assembly, following the procedures in (1) through (3) above.
- (5) Replace the remaining guyband assemblies, following the procedures in (1) through (4) above.

b. Side Buckles.

- (1) Loosen the strap, and remove the slide buckle from the floor unit.
- (2) Remove the slide buckle from the strap.
- (3) Install a serviceable slide buckle, reversing the procedures in (1) and (2) above.

- (4) Replace the remaining slide buckles, following the procedures in (1) through (3) above.

c. Tie Down, Strap End Clips.

- (1) Cut any frays from the end of the tie down strap.
- (2) Place a new end clip on the tie down strap, and flatten it with a hammer.

Note. Be certain the end clip is securely mounted on the tie down strap.

- (3) Replace the remaining tie down strap end clips, following the procedures in (1) and (2) above.

Section VI. TENT ACCESSORIES

35. General

The only tent accessory furnished with this tent is the connector-switch. The connector-switch consists of four junction boxes with lamps connected together and to a switch box with an electrical cord. When the tent is erected and the connector-switch is connected to a suitable outside source of electricity, the connector switch in the ON position will supply electricity to light the interior of the tent.

36. Maintenance of the Connector-Switch

a. Inspect.

- (1) Inspect the lamps for dirt and proper operation.
- (2) Inspect the cord hangers and cord clips for bends, breaks, and dirt.
- (3) Inspect the electrical cord for cut, broken, deteriorated or dirty insulation.
- (4) Inspect the junction boxes for cracks, breaks poor connections, or dirt.
- (5) Inspect the switch box for tents, cracks, or broken switch.

b. Service. Use a clean, dry cloth to remove any loose dirt from the connector-switch parts.

37. Replacement of the Connector-Switch and Parts

a. Lamps.

- (1) Place the switch in the OFF position.

Note. Insure that the switch at power source is also in the OFF position.

- (2) Unscrew and remove the lamp from the outlet socket.
- (3) Screw a serviceable lamp into the outlet socket.
- (4) Replace the remaining lamps, following the procedures in (1) through (3) above.

b. Cord Clips.

- (1) Loosen the wing nuts, and remove the cord clip from the door frame and door assembly.
- (2) Bend the cord clip, and remove it from the electrical cord.
- (3) Bend a serviceable cord slip around the electrical cord at the desired location.
- (4) Hook the cord clip on the bolt, and tighten the wing nut.

c. Cord Hangers.

- (1) Remove the cord hanger from the arch purlin.
- (2) Bend the cord hanger, and remove it from the electrical cord.
- (3) Bend a serviceable cord hanger around the electrical cord at the desired location, and hook the cord hanger on the arch purlin.

(4) Replace the remaining cord hangers, following the procedures in (1) through (3) above.

d. *Connector-Switch.* Replace the connector-switch, following the procedures in paragraphs 12d and 13b.

CHAPTER 4

DIRECT SUPPORT MAINTENANCE INSTRUCTIONS

Section I. TENT BODY

38. Maintenance of the Tent Body

a. *Inspect.* Follow the inspection procedures in TM 10-269.

b. *Mark.* Mark the tent body for repair as stated in TM 10-269.

39. Repair and Fabrication of the End Blanket Assembly Parts

a. *Repair.*

(1) *Locking channels.*

(a) Remove the wing nuts and flat washers from the locking channel bolts, and remove the locking channel from the door frame and door assembly.

(b) Install a serviceable locking channel on the door frame and door assembly, reversing the procedures in (a) above.

(c) Replace the remaining locking channels, following the procedures in (a) and (b) above.

(2) *Footstop clips.*

(a) Using a chisel, cut the rivets, and remove the footstop clip from the door frame and door assembly.

(b) Install a serviceable footstop in a serviceable footstop clip, and weld the ends together.

(c) Using new rivets, install the footstop clip on the door frame and door assembly.

(d) Replace the remaining footstop clips, following the procedures in (a) through (c) above.

(3) *Transom blackout flaps and tie tapes.*

(a) Remove the nails from the wooden moulding, and remove the wooden moulding, the transom blackout flap, and tie tapes from the transom.

(b) Cut a new transom blackout flap (11 7/8 inches by 2 3/8 inches) from the bulk cloth (FSN 8305-2489575).

(c) Make a 1/2-inch fold along each edge of the transom blackout flap, and machine-sew it with a single row of stitching.

(d) Cut two tie tapes (24 inches long) from the bulk tape (FSN 8315-2536289).

(e) Install the new transom blackout flap and the tie tapes on the transom as shown in figure 11.

Note. A tie tape will be installed at the second nail from each end of the wooden moulding.

(f) Replace the remaining transom blackout flap and tie tapes, following the procedures in (a) through (e) above.

(4) *Transom screens.*

(a) Remove the nails from the wooden moulding, and remove the wooden moulding and the screen from the door frame and door assembly.

(b) Cut a new screen (11 1/2 inches by 21 1/2 inches) from the bulk wire fabric (FSN 5335-228-9750).

(c) Place the new screen on the door frame and door assembly, and in

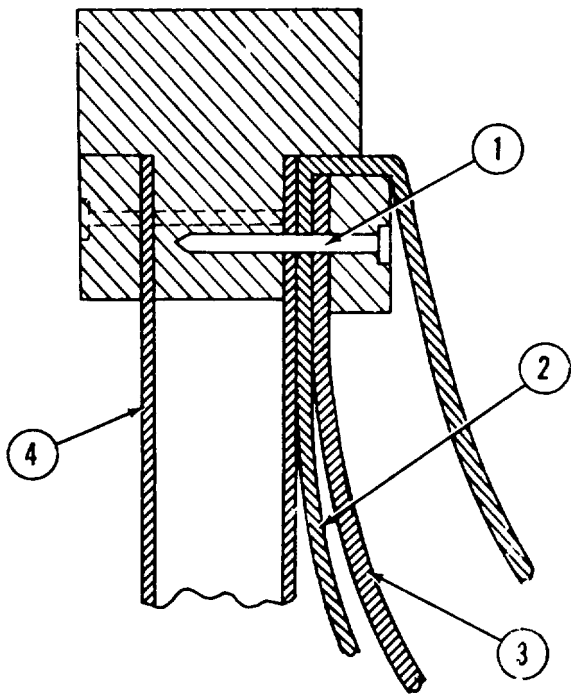

MEC 8340-210-13/11

- | | | | |
|---|----------|---|----------------------|
| 1 | Nail | 3 | Flap, blackout |
| 2 | Tie Tape | 4 | Window pane, transom |

Figure 11. End view of transom blackout flap.

stall the wooden moulding around the edges.

- (d) Replace the remaining transom screen, following the procedures in (a) through (c) above.
- (5) *Transom window pane.*
 - (a) Remove the nails from the wooden moulding, and remove the wooden moulding from the transom.
 - (b) Remove the transom window pane from the transom.
 - (c) Install a new transom window pane, reversing the procedures in (a) through (b) above.
 - (d) Replace the remaining transom window pane, following the procedures in (a) through (c) above.
- (6) *Tent door threshold.*
 - (a) Cut the rivets, and remove the tent door threshold from the door frame and door assembly.
 - (b) Place a serviceable door threshold on the door frame and door assembly.
 - (c) Install new rivets in the door threshold.
 - (d) Replace the remaining tent door threshold, following the procedures in (a) through (c) above.
- (7) *Door frame and door assemblies.*
 - (a) Remove the nails from the wooden moulding on each side of the door, frame and door assembly, and remove the wooden moulding from the door assembly.
 - (b) Remove the wooden moulding from the top of the door frame and door assembly, and remove the door frame and door assembly from the end blanket assembly.
 - (c) Cut the rivets, and remove the tent door threshold from the door frame and door assembly.
 - (d) Install a serviceable frame and door assembly on the end blanket assembly, reversing the procedures in (a) and (b) above.
 - (e) Place a serviceable tent door threshold on the door frame and door assembly.
 - (f) Install new rivets in the tent door threshold.
 - (g) Replace the remaining door frame and door assembly, by following the procedures in (a) through (f) above.
- (8) *Arch tie down chape and buckle.*
 - (a) Cut the stitching, and remove the arch tie down chape from the retainer on the end blanket assembly.
 - (b) Remove the double bar buckle from the arch tie down chape.
 - (c) Cut a new arch tie down chape (25 inches long) from the bulk webbing (FSN 8305-263-2477).
 - (d) Place an end clip on one end of the arch tie down chape, and flatten it with a hammer.
 - (e) Place a double bar buckle on the opposite end of the arch tie down

- chape, and fold back 4½ inches of the arch tie down chape.
- (f) Install the arch tie down chape under the retainer, and machine sew it with the original stitching.
 - (g) Replace the remaining arch tie down chapes and buckles, following the procedures in (a) through (f) above.
- (9) *Tie down hook chapes.*
- (a) Cut the stitching, and remove the tie down hook chape from the end blanket assembly.
 - (b) Cut a new tie down hook chape (14 inches long) from the bulk webbing (FSN 8305-263-2477).
 - (c) Place an end clip on one end of the tie down hook chape, and flatten it with a hammer.
 - (d) Fold under a ¾-inch length on the opposite end of the tie down hook chape, and machine sew it to the end blanket assembly with the original stitching.
 - (e) Install a serviceable slide buckle on the tie down hook chape.
 - (f) Replace the remaining tie down hook chapes, following the procedures in (a) through (e) above.
- (10) *Window blackout flap retainers.*
- (a) Cut the stitching from the window blackout flap retainers, and remove the retainer from the end blanket assembly.
 - (b) Cut a new window blackout flap retainer (6 inches by 34½ inches) from the bulk cloth (FSN 8305248-9574).
 - (c) Fold under a 1-inch length along each edge of the window blackout flap retainer, and machine-sew it to the end blanket assembly with the original stitching.
 - (d) Replace the remaining window blackout flap retainers, following the procedures in (a) through (c) above.
- (11) *Window blackout flap tie tapes.*
- (a) Remove the stitching from the window blackout flap tie tapes and the end blanket assembly.
 - (b) Cut a new tie tape from the bulk tape (FSN 8315-253-6289).
- Note. Cut tie-up tie tapes 24 inches long and all others 12 inches long.**
- (c) Replace the remaining window blackout flap tie tapes, following the procedures in (a) and (b) above.
- (12) *Window blackout flaps.*
- (a) Remove the necessary stitching from the end blanket assembly, and remove the window blackout flap from the end blanket assembly.
 - (b) Cut a new window blackout flap (26 inches by 323/ inches) from the bulk cloth (FSN 8305-248-9575).
 - (c) Fold under 1-inch along the bottom of the window blackout flap, and machine-sew it with a single row of stitching.
 - (d) Fold under one-half inch along each side of the window blackout flap, and machine-sew it with a single row of stitching.
 - (e) Cut two new tie tapes (12 inches long) from the bulk tape (FSN 8315-253-6289), and machine-sew them to the bottom of the window blackout flap to align with the matching tie tapes on the end blanket assembly.
 - (f) Place the window blackout flap on the end blanket assembly, and machine-sew it with the original stitching.
 - (g) Replace the remaining window blackout flaps, following the procedures in (a) through (e) above.
- (13) *Window screens.*
- (a) Remove the nails from the wooden moulding on the outside edges of the window screen, and remove the moulding and window screen from the window.
 - (b) Cut a new window screen (14¼ inches by 20¼ inches) from the

- bulk wire fabric (FSN 5335-2289750).
- (c) Place the window screen over the window, and secure the wooden moulding in place with the proper nails.
 - (d) Replace the remaining window screen, following the procedures in (a) through (c) above.
- (14) *Window panes.*
- (a) Remove the nails from the wooden moulding, and remove the necessary moulding from the window assembly.
 - (b) Remove the window pane from the window assembly.
 - (c) Place a serviceable window pane in the window assembly, and nail the wooden moulding in place around it.
 - (d) Replace the remaining window panes, following the procedures in (a) through (c) above.
- (15) *Window assemblies*
- (a) Remove the wooden batten from around the inside and outside of the window assembly.
 - (b) Remove the tacks securing the end blanket assembly to the window assembly.
 - (c) Remove the window assembly from the end blanket assembly.
 - (d) Install a serviceable window assembly, reversing the procedures in (a) through (c) above.
 - (e) Replace the remaining window assemblies, following the procedures in (a) through (d) above.
- (16) *Securing lines.*
- (a) Cut the stitching, and remove the securing line from the end blanket assembly.
 - (b) Cut a new securing line (33 feet 4 inches long) from the bulk rope (FSN 4020-719-4609).
 - (c) Place the securing line along the edge of the end blanket assembly, and fold 1 7/8 inches of the end
- blanket assembly over the blanket securing line. Machine-sew the fold with the original stitching.
- (d) Replace the securing line on the remaining end blanket assembly, following the procedures in (a) through (c) above.
- (17) *Securing lugs.*
- (a) Cut the necessary stitching along the side and bottom of the end blanket assembly, and separate the inside cloth from the outside cloth.
 - (b) Cut the stitching, and remove the securing lug from the inside cloth.
 - (c) Using the damaged securing lug as a pattern, cut a new one from the bulk cloth (FSN 8305-248-9574). Machine-sew the new securing lug with the same stitching as the old securing lug.
 - (d) Install two grommets in the securing lug follow in,, the instructions in TM 10-633.
 - (e) Machine-sew the securing lug to the inside cloth, with the original stitching. Machine-sew the inside and outside cloth together with the original stitching.
 - (f) Install a securing line in the securing lug, and the an overhand knot in each running end.
 - (g) Replace the remaining securing lugs, following the procedures in (a) through (f) above.
- b. *Fabrication.*
- (1) *Door frame footstops.*
 - (a) Using the proper cutting tools, cut new door frame footstops (15 inches long) from the bulk chain (FSN 4010-221-0738).
 - (b) Make an open link, and weld ends of chain together, following the instructions in TM 9-237.
 - (2) *Tent door gaskets.* Cut new tent door gaskets (4½ inches by 32½ inches) from the bulk cloth (FSN 8305-248-9575).

40. Repair of the Roof Blanket Assembly Parts

a. Tie Down Hook Chapes.

- (1) Cut the stitching, and remove the tie down hook chape from the roof blanket assembly.
- (2) Cut a new tie down hook chape (14 inches long) from the bulk webbing (FSN 8305-297-6833).
- (3) Place an end clip on one end of the tie down hook chape, and flatten it with a hammer.
- (4) Machine-sew the tie down hook chape to the roof blanket assembly with the original stitching.
- (5) Install a slide buckle on the end of the tie down hook chape.
- (6) Replace the remaining tie down hook chapes, following the procedures in (1) through (5) above.

b. Securing Lines.

- (1) Cut the stitching along the edge of the roof blanket assembly, and remove the securing line from the roof blanket assembly.
- (2) Cut a new securing line (22 feet 4 inches long) from the bulk rope (FSN 4020-719-4609).
- (3) Place the securing line on the roof blanket assembly, and fold over 1 7/8 inches along the edge of the roof blanket assembly.
- (4) Machine-sew the fold with the original stitching.
- (5) Replace the remaining securing lines, following the procedures in (1) through (4) above.

c. Securing Lugs.

- (1) Cut the necessary stitching, and separate the inside cloth from the outside cloth.
- (2) Cut the stitching, and remove the securing lug from the inside cloth of the roof blanket assembly.
- (3) Using the unserviceable securing lug as a guide, cut a new securing lug from the bulk cloth (FSN 8305-2489574).

- (4) Install two grommets (FSN 5325641-0405) in the securing lug (TM 10-633).
- (5) Machine-sew the securing lug edges like the unserviceable one.
- (6) Machine-sew the securing lug to the inside cloth with the original stitching.
- (7) Machine-sew the inside and outside cloth together with the original stitching.
- (8) Install a securing line in one of the grommets on the securing lug, and tie an overhand knot in each running end of the securing line.
- (9) Replace the remaining securing lugs, following the procedures in (1) through (8) above.

41. Repairs of Vestibule End Cover and Top Cover Parts

a. Tie Down Chape.

- (1) Cut the stitching, and remove the tie down chape from the vestibule end cover or the vestibule top cover.
- (2) Cut a new tie down chape (14 inches long) from the bulk webbing (FSN 8305-263-2477).
- (3) Place an end clip on one end of the tie down chape, and flatten it with a hammer.
- (4) Machine-sew the tie down chape to the vestibule end cover or the vestibule top cover with the original stitching.
- (5) Install a slide buckle on the tie down chape.
- (6) Replace the remaining vestibule end cover tie down chapes and the remaining top cover tie down chapes, following the procedures in (1) through (5) above.

b. End Cover Securing Lug.

- (1) Cut the stitching and remove the securing lug from the end cover.
- (2) Using the unserviceable securing lug as a pattern, cut a new securing lug (4 inches by 5 1/2 inches) from the bulk cloth (FSN 8305-248-9575).

- (3) Install two grommets (FSN 5325-641-0405) in the securing lug.
 - (4) Machine-sew the securing lug to the end cover with the original stitching.
 - (5) Install a securing line through one of the grommets, and tie an overhand knot ill each running end.
 - (6) Replace the remaining end cover securing lugs, following the procedures in (1) through (5) above.
- c. *End Cover Gussets.*
- (1) Cut the rivets from the gusset, and remove the gusset from the end cover retainer.
 - (2) Place the serviceable gusset on the end cover retainer, and install new rivets ('FSN 5320-584-9167), following the instructions in TM 10269.
 - (3) Replace the remaining gusset and rivets, following the procedures in (1) and (2) above.
- d. *End Cover Retainer.*
- (1) Remove the wood screws from the purlin clip, and remove it from the end cover retainer.
 - (2) Remove the end cover gussets (c(1) above).
 - (3) Remove the wood screws from the binding strip, and remove the binding strip and the end cover from the end cover retainer.
 - (4) Install the binding strip end cover on the serviceable end cover retainer, reversing the procedures in (3) above.
 - (5) Install the end cover gussets on the end cover retainer (c(2) above).
 - (6) Install the purlin clip on the end cover retainer, reversing the procedure in (1) above.
- e. *Top Cover Securing Lines.*
- (1) Remove the necessary stitching from the top cover, and remove the securing line from the top cover.
 - (2) Cut a new top cover securing line (9 feet long) from the bulk rope (FSN 4020-719-4609), and place it on the top cover.
 - (3) Fold 1 3/8 inches of the top cover over the securing line, and machine--sew the fold with the original stitching.
 - (4) Replace the remaining top cover securing line, following the procedures in (1) through (3) above.

Section II. TENT SUPPORT COMPONENTS

42. Maintenance of the Tent Support Components

a. *Inspect.* Follow the inspection procedures in TM 10-269.

b. *Mark.* Mark the tent support components for repair.

43. Repair and Fabrication of the Arch Parts

a. *Repair.*

(1) *Arch clips, footstop clips, and ferrules.*

- (a) Cut the arch clip rivet, and remove the arch clip and the arch clip rivet from the arch.
- (b) Remove the wood screw from the footstop clip, and remove the footstop clip from the arch.
- (c) Remove the wood screws from the ferrule, and remove the ferrule from the arch.

(d) Place a serviceable ferrule on the arch, and install the wood screws in the ferrule and arch.

(e) Place a serviceable footstop clip on the arch, and secure it with a wood screw.

(f) Place a serviceable arch clip on the arch, and install a new rivet (FSN 5320-101-4090), following the instructions in TM 10-633.

(g) Replace the remaining arch clips, footstop clips, and ferrules, following the procedures in (a) through (f) above.

(2) *Type B ferrules.*

(a) Remove the wood screws from the

- ferrule, and remove the ferrule from the arch.
 - (b) Place a serviceable ferrule on the arch, and install the wood screws through the ferrule and into the arch.
 - (c) Replace the remaining type B ferrules, following the procedures in (a) and (b) above.
- (3) *Connector leaves and ferrules.*
- (a) Cut the rivets, and remove them from the connector leaf.
 - (b) Remove the connector leaves from the arch.

Note.

Be certain to note the type connector leaf removed from each side.

- (c) Remove the safety chain and headed pin from the type A connector leaf.
 - (d) Remove the wood screws from the the ferrule, and remove the ferrule from the arch.
 - (e) Place a serviceable ferrule on the arch, and secure it to the arch with the wood screws.
 - (f) Use a new cotter pin to install the safety chain and headed pin on the serviceable type A connector leaf.
 - (g) Place the serviceable connector leaves on the arch, and install new rivets (FSN 5320-010-4091), following the instructions in TM 10633.
 - (h) Replace the remaining connector leaves and ferrules, following the procedures in (a) through (e) above.
- (4) *Arch purlin clips.*
- (a) Cut the rivets, and remove them from the arch and arch purlin clip.
 - (b) Place a serviceable arch purlin clip on the arch, and secure it to the arch with new rivets (FSN 5320-010-4090), following the riveting procedures in TM 10-633.

- (c) Replace the remaining arch purlin clips, following the procedures in (a) and (b) above.

b. Fabrication of Footstops.

- (1) Cut new footstops (15 inches long) from the bulk chain (FSN 4010-221-0738).
- (2) Install an open link in one end of each footstop.

44. Repair of Vestibule Parts

a. Floor Panel.

- (1) Remove the nails and wood screws from vestibule floor frame, and remove the floor panel from the vestibule floor.
- (2) Cut a new floor panel (35 7/8 inches by 46 1/4 inches) from the bulk plywood FSN 5330-129-2154).
- (3) Place the new floor panel on the vestibule floor, and install the nails and wood screws in the vestibule floor frame and floor panel.
- (4) Paint the floor panel (para 23c(2)).

b. Panel and Door Assembly and Side Panel Assembly.

(1) *Steel angles.*

- (a) Cut the rivets from the steel angle, and remove the steel angle from the panel and door assembly.
- (b) Place a serviceable steel angle on the panel and door assembly, and install new rivets, following the instructions in TM 10-633.
- (c) Replace the steel angle on the side panel assembly, following the instructions in (a) and (b) above.

(2) *Purlin clips.*

- (a) Cut the rivets, and remove the purlin clip from the panel and door assembly.
- (b) Place a serviceable purlin clip on the panel and door assembly, and install new rivets, following the instructions in TM 10-633.
- (c) Replace the purlin clip on the side panel assembly, following the procedures in (a) and (b) above.

(3) *Gusset connector wing nuts and bolts.*

- (a) Remove the wing nuts from the bolts, and remove the bolts from the gusset connector.
 - (b) Install new bolts and wing nuts in the gusset; connector, and peen the end of each bolt.
 - (c) Replace the remaining gusset connector wing nuts and bolts, following the procedures in (a) and (b) above.
- (4) *Gusset connectors.*
- (a) Cut the rivets, and remove the gusset connector from the panel and door assembly.
 - (b) Place a serviceable gusset connector on the panel and door assembly, and install new rivets (FSN 5320-010-4092) following the instructions in TM 110-633.
 - (c) Replace the gusset connector on the door panel assembly, following the procedures in (a) and (b) above.

45. Repair of Purlins

- a. *Vestibule and Arch Purlins.*
 - (1) Cut the rivets, and remove the purlin angle from each end of the purlin.
 - (2) Place a serviceable purlin angle on each end of the purlin, and install new rivets (FSN 5320-010-6905) following the instructions in TM 10-633.
 - (3) Replace the purlin angles on the remaining vestibule and arch purlins, following the procedures in (1) and (2) above.
- b. *Tent End Purlins.*
 - (1) Cut the rivets from the fixed connector on the tent end purlin, and remove the fixed connector from the tent purlin.
 - (2) Place a serviceable fixed connector on the tent end purlin, and install the rivets (FSN 5320-010-6905) following the instructions in TM 10-633.

- (3) Replace the fixed connector on the remaining tent end purlin, following the procedures in (1) and (2) above.

46. Repair of Tent Floor Parts

- a. *Roto-Lock Fasteners.*
 - (1) Remove the nuts from the mounting bolts, and remove the bolts from the roto-lock fastener.
 - (2) Remove the roto-lock fastener from the floor unit.
 - (3) Place a serviceable roto-lock fastener on the floor unit, and install the mounting bolts and nuts.
 - (4) Replace the remaining roto-lock fasteners, following the procedures in (1) through (3) above.
- b. *Key Retainers.*
 - (1) Remove the tacks from each end of the key retainer, and remove the key retainer from the floor unit.
 - (2) Cut a new key retainer (8 inches long) from the tape (FSN 8315-253-6290).
 - (3) Install a new snap fastener (FSN 5325-286-9556) halfway between the ends of the key retainer, following the instructions in TM 10-269.
 - (4) Fold under one-half inch on each end of the key retainer, and tack the ends in place on the floor unit.
 - (5) Replace the remaining key retainers, following the procedures in (1) through (4) above.
- c. *Snap Fastener Studs.*
 - (1) Remove the stud from the floor unit.
 - (2) Install a new snap fastener stud (FSN 5325-281-3991), in place.
 - (3) Replace the remaining snap fastener studs, following the procedures in (1) and (2) above.
- d. *Top Floor Panels.*
 - (1) Remove the necessary nails and wood screws from the floor unit to remove the top floor panel.

- (2) Remove the top floor panel from the floor unit.
- (3) Cut a new floor panel (46 3/4 inches by 8 feet) from the bulk plywood (FSN 5530-129-2125).
- (4) Apply a coat of coating primer (FSN 8010-161-7425) to floor panel and allow it to dry to the touch. Apply a coat of enamel (FSN 8010-297-2124) over the primed area.
- (5) Place the top floor panel on the floor unit, and install the nails and wood screws to secure it to the floor unit.
- (6) Replace the remaining top floor panels, following the procedures in (1) through (4) above.

e. *Bottom Floor Panels.*

- (1) Remove the necessary nails and wood screws from the floor unit, and remove the bottom floor panels.
- (2) Cut a new bottom floor panel (43 7/16 inches by 7 feet 9 3/4 inches from the bulk plywood (FSN 5530-129-2097).
- (3) Apply a coat of coating primer (FSN 8010-161-7425) to floor panel and allow it to dry to the touch. Apply a coat of enamel (FSN 8010-297-2124) over the primed area.
- (4) Place the bottom floor panel on the floor unit, and install the nails and wood screws to secure it to the floor unit.
- (5) Replace the remaining bottom floor panels, following the procedures in (1) through (3) above.

Section III. TENT ANCHORING COMPONENTS AND TENT ACCESSORIES

47. Repair of the Guyband Assemblies

a. *Tent Guy Line Chapes and Dee Rings.*

- (1) Remove the stitching from the chape, and remove the chape with the dee ring and tent guy line from the guyband assembly.
- (2) Remove the dee ring and tent guy line from the chape, and remove the tent guy line from the dee ring.
- (3) Cut a new chape (14 inches long) from the bulk webbing (FSN 8305-263-2479).
- (4) Fold the chape, in half, and place a serviceable dee ring on one end.
- (5) Place the chape on the guyband assembly. and machine-sew it with the original stitching.
- (6) Replace the remaining chapes and dee rings, following the procedures in (1) Through (5) above.

b. *Tie Down Hook Straps, Securing Lines, and Dee Rings.*

- (1) Remove the tie down hook from the strap.
- (2) Cut the stitching, and remove the strap from the dee ring.

- (3) Cut the securing line splice, and remove the dee ring from the securing line.
- (4) Repeat the procedures in (1) through (3) for repair of the remaining end of the securing line, and remove the securing line from the guyband assembly.
- (5) Cut the stitching along the edge of the guyband assembly.
- (6) Cut a new securing line (24 feet long) from the bulk rope (FSN 4020-719-4609), and place it along the edge of the guyband assembly.
- (7) Fold the edge of the guyband assembly over the securing line, and machine-sew the fold with the original stitching.
- (8) E)e-splice a serviceable dee ring in each end of the securing line (TM 10-269).
- (9) Cut a new strap (32 inches long) from the bulk webbing (FSN 8305-263-2477).
- (10) Fold back three-fourths of an inch on one end of the strap, and make a 1 3/4-inch fold through the dee ring.

- (11) Machine-sew the dee ring strap with a single-X-box-stitch formation.
- (12) Place an end clip on the remaining end of the strap, and flatten it with a hammer.
- (13) Install a tie down hook on the strap.
- (14) Repeat the procedures in (8) through (13) for repair of the remaining end of the securing line.
- (15) Replace the remaining tie down hook straps, securing lines, and dee rings, following the procedures in (1) through (14) above.

48. Repair of Connector-Switch Parts

a. Switch Box, Bracket, and Electrical Connector.

- (1) Remove the screws (17, fig. 12) from the switch box cover (16), and pull the switch box cover from the switch box.
- (2) Loosen the screws, and disconnect the cord (1) from the switch box cover.
- (3) Remove the cord from the switch box.
- (4) Remove the nut (18) from the connector (19), and remove the connector from the switch box.

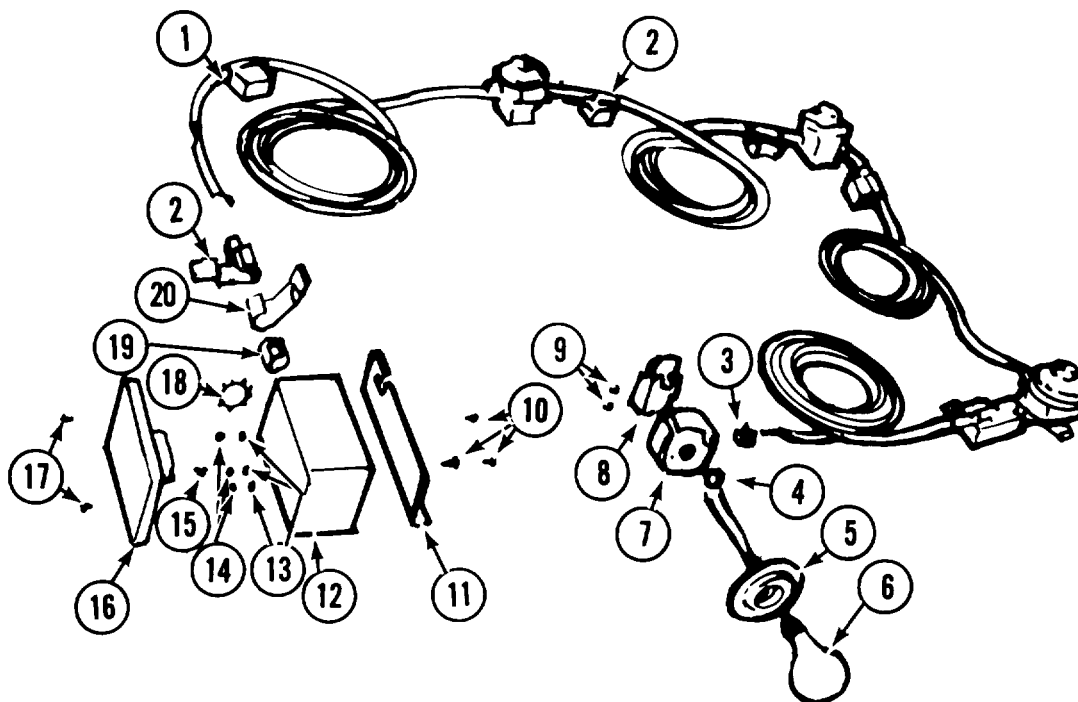

MEC 8340-210-13/12

1	Cord, electrical	8	Hanger, outlet	15	Nut, wing
2	Clip, cord	9	Rivets	16	Cover, switch box
3	Connector, electrical	10	Screws, machine	17	Screws
4	Nut	11	Bracket	18	Nut, connector
5	Plate	12	Switch Box	19	Connector, electrical, watertight
6	Lamp	13	Washers, lock	20	Hanger, cord
7	Junction Box	14	Nuts		

Figure 12. Connector switch.

- (5) Remove the nuts (14) and lockwashers (13) from the screws (10), and remove the screws from the bracket (11).
- (6) Remove the wingnut (15), nut (14), and lockwasher (13) from the remaining screw (10), and remove the screw from the bracket.
- (7) Remove the bracket from the switch box.
- (8) Install a new switch electrical connector and the bracket, reversing the procedures in (1) through (7) above.

b. Junction Boxes, Outlet Hangers, Electrical Connectors and Plates.

- (1) Remove the lamp (6, fig. 12) from the plate (5).
- (2) Loosen the two screws securing the plate to the junction box (7), and remove the plate.
- (3) Disconnect the cord at the plate, loosen the screws on the connector, and remove the cord from the junction box.
- (4) Remove the nut (4) from the connector (3), and remove the connector from the junction box.
- (5) Cut the rivets (9), and remove the hanger (8) from the junction box.
- (6) Use new rivets, and install a serviceable hanger on a serviceable junction box, following the rivet installation procedures in TM 10-269.
- (7) Install serviceable connector and plate, reversing the procedures in (1) through (4) above.
- (8) Replace the remaining junction boxes, outlet hangers, electrical connectors, and plates, following the procedures in (1) through (7) above.

c. Electrical Cord.

(1) Switch box to junction box.

- (a) Remove the screws (17, fig. 12) from the switch box cover (16), and pull the switch box cover from the switch box (12).
- (b) Loosen the screws, and remove the cord (1) from the switch box.
- (c) Loosen the two screws securing the plate (5) to the junction box (7), and remove the plate from the junction box.
- (d) Disconnect the cord from the plate.
- (e) Loosen the screws on the connector (3), and remove the cord from the junction box.
- (f) Using the unserviceable cord as a pattern, cut a new cord from the bulk cable (FSN 6145-283-9475).
- (g) Install a serviceable cord in the junction box and the switch box, following the procedures in (a) through (f) above.

(2) Junction box to junction box.

- (a) Follow the procedures in (1)(c) through (e) above, and remove the cord at each junction box.
- (b) Using the unserviceable cord as a pattern, cut a new cord from the bulk cable (FSN 6145-283-9475).
- (c) Install a serviceable cord, reversing the procedures in (1)(c) through (e) above.

CHAPTER 5

SHIPMENT AND LIMITED STORAGE AND DEMOLITION TO PREVENT ENEMY USE

Section I. SHIPMENT WITHIN CONUS

49. General

These instructions apply to the tent that is to be ready for assembly and use upon arrival from shipment. These instructions do not apply to the tent being shipped overseas.

50. Preparation of Equipment for Shipment

a. Inspection.

- (1) Perform the daily preventive maintenance services (para 22).
- (2) Correct all deficiencies found during the inspection.

b. *Striking Tent.* Follow the procedures in paragraph 15 to strike the tent.

c. *Cleaning and Painting.*

- (1) Clean the tent components as necessary, and remove the rust and corrosion from all the metal parts. Allow the tent components to dry before packing them.
- (2) Remove all damaged paint, and repaint the surfaces with olive drab green enamel (FSN 8010-297-2124).

d. *Crating Tent.*

- (1) Use the proper materials to construct a crate with inside dimensions of 7 feet, 2 inches long, 4 feet 0 inches wide, and 1 foot 6 inches high. Use the proper blocking, and place the vestibule components in the crate. Place the top on

the crate, and secure it with nails and 3/4-inch metal banding.

- (2) Fold each roof arch, and use the proper materials to construct a crate for each end and middle of each arch.
Install the protective cases on the arches.
- (3) Prepare the remaining tent components in accordance with instructions in paragraph 14a.
- (4) Use the proper materials to strap the floor units.
- (5) Be certain all the necessary shipping information is securely attached to each crate.

51. Loading and Blocking Crates on Railroad Cars

a. Open car loading will be in accordance with instructions in section No. 6, Association of American Railroads operations.

Note.

Protect the crates with a shroud of waterproof barrier.

b. Closed car loading will be in accordance with instructions in pamphlet No. 14 of Association of American Railroads.

Section II. LIMITED STORAGE

52. General

These instructions apply to the tent that is to be stored for a period not to exceed 6 months. These

instructions are not adequate for the tent that will be in storage longer than 6 months.

53. Preparation of Equipment for Storage

a. Inspection.

- (1) Perform the daily preventive maintenance services (para 20).
- (2) Correct all deficiencies found during the inspection.

b. *Striking Tent.* Follow the procedures in paragraph 13 to strike the tent.

c. Cleaning and Painting.

- (1) Clean the tent components as necessary, and remove the rust and corrosion from the metal parts. Allow the tent components to dry before packing them.
- (2) Remove all damaged paint, and repaint the surfaces with olive drab green enamel (FSN 8010-297-2124).

d. *Crating Tent.* Prepare the tent in accordance with instructions in paragraph 50d.

54. Storing Tent

Note.

If the tent is stored outside, the packing crates must be covered with the proper waterproof cover.

- a. Move the packing crates to the storage shelter, and place the vestibule crate on the proper blocking.
- b. Use the proper blocking, and stack the floor unit packing crates on the vestibule crate.
- c. Place the arches on the proper blocking beside the packing crates.

Section III. DEMOLITION OF MATERIEL TO PREVENT ENEMY USE

55. Authority

The tent will be destroyed only if there is danger of capture and use by the enemy, and only after the order is given by the unit commander. Destroy the same parts on all similar equipment to prevent salvage by the enemy.

56. Methods

Observe **Warning.** **safety**
precautions. **adequate**

a. *Destruction by Hand.*

- (1) Smash or cut the items listed below with an axe.
 - (a) Floor units
 - (b) Floor runners
 - (c) Arches

- (d) Purlins
- (e) Vestibule
- (f) Doors
- (g) Windows

(2) Cut the items listed below with a knife.

- (a) Electrical cord
- (b) Roof blanket assemblies
- (c) Guyband assemblies
- (d) End blanket assemblies

b. *Destruction by Misuse.*

- (1) Place all the tent components in a pile, and set them afire.
- (2) Remove the hardware from the tent components, and bury it in the ground or throw it into a body of water.

APPENDIX I

REFERENCES

1. Dictionaries of Terms and Abbreviations

AR 320-5 Dictionary of United States Army Terms.
AR 320-50 Authorized Abbreviations and Brevity Codes.

2. Fire Protection

SB 5-111 Supply of DA Approved Fire Extinguishers to Army Troop Users.
TM 5-687 Repair and Utilities: Fire Protection Equipment and Appliances:
Inspections, Operations, and Preventive Maintenance.
TM 9-1799 Ordnance Maintenance; Fire Extinguishers.

3. Painting

TM 9-213 Painting Instructions for Field Use.

4. Preventive Maintenance

AR 750-5 Organization, Policies, and Responsibilities for Maintenance Operation.
TM 10-633 Canvas Repair Kit.
TM 38-750 Army Equipment Record Procedures.

5. Publication Indexes

DA Pam 108-1 Index of Army Motion Pictures, Film Strips, Slides, and Phono-Recordings.
DA Pam 310-1 Index of Administrative Publications.
DA Pam 310-2 Index of Blank Forms.
DA Pam 310-3 Index of Training Publication.
DA Pam 310-4 Index of Technical Manuals, Technical Bulletins, Supply Manuals
(Types 4, 6, 7, 8, and 9), Supply Bulletins, Lubrication Orders,
and Modification Work Order.
DA Pam 310-5 Index of Graphic Training Aids and Devices.
DA Pam 310-25 Index of Supply Manuals--Corps of Engineers.

6. Shipment and Limited Storage

TM 9-200 General Packaging Instructions for Ordnance General Supply.
TM 38-230 Preservation, Packaging, and Packing of Military Supplies and Equipment.

7. Supply Publications

TM 10-8340-210-23P Organizational and Direct Support Maintenance Repair Parts.

8. Training Aids

FM 5-20

FM 5-25

FM 20-15

FM 21-5

FM 21-6

FM 21-30

Camouflage, Basic Principles and Field Camouflage.

Explosive and Demolitions.

Tents and Tent Pitching.

Military Training.

Techniques of Military Instruction.

Military Symbols.

APPENDIX II

BASIC ISSUE ITEMS LIST

Section I. INTRODUCTION

1. General

Section II lists the accessories, tools, and publications required for maintenance and operation by the operator, initially issued with, or authorized for the tent, frame type.

2. Explanation of Columns Contained in Section II

a. Source Codes. The information provided in each column is as follows:

- (1) *Material.* This column is left blank for identification of agencies assigned supply responsibility for parts, refer to appropriate Federal and Department of the Army supply catalogs.
- (2) *Source.* The selection status and source of supply for each part are indicated by one of the following code symbols:
 - (a) P-applied to high mortality repair parts which are stocked in or supplied from the supply service depot system, and authorized for use at indicated maintenance level.
 - (b) P1-applied to repair parts which are low-mortality parts, stocked in or supplied from supply service depots, and authorized for installation at indicated maintenance level.
- (3) *Maintenance.* The lowest maintenance level authorized to use, stock, install, or manufacture the part is indicated by the following code symbol:
O-Organizational Maintenance
- (4) *Recoverability.* When no code is shown in the recoverability column the part is considered expendable.

b. Federal Stock Number. When a Federal stock number is available for a part, it will be shown in this column, and will be used for requisitioning purposes.

c. Description.

- (1) The item name and a brief description of the part are shown.
- (2) A five-digit Federal supply code for manufacturers and/or other supply services is shown in parentheses followed by the manufacturer's part number. This number shall be used for requisitioning purposes when no Federal stock number is indicated in the Federal stock number column. Example: (08645) 86543

d. Unit if issue. If no abbreviation is shown in this column, the unit of issue is "each".

e. Quantity Authorized. This column lists the quantities of repair parts, accessories, tools, or publications authorized for issue to the equipment operator or crew as required.

f. Quantity issued with Equipment. This column lists the quantities of repair parts, accessories, tools, or publications that are initially issued with each item of equipment. Those indicated by an asterisk are to be requisitioned through normal supply channels as required.

g. Illustrations. This column is subdivided into two columns which provide the following information:

- (1) *Figure number.* Provides the indentifying number of the illustration.
- (2) *Item number.* Provides the referenced number for the parts shown in the illustration.

Section II. BASIC ISSUE ITEMS LIST

Source codes				Federal Stock No.	Description	Unit of Issue	Quantity Authorized	Quantity Issued Equipment	Illustration	
Materiel Issue	Source	Maintenance	Recoverability						Fig.	Item.
					GROUP 31-BASIC ISSUE ITEMS MANUFACTURER INSTALLED 3100-BASIC ISSUE ITEMS, MANUFACTURER OR DEPOT INSTALLED					
	P	O		7520-559-9618	CASE: maintenance and operational manuals, cotton duck, water repellant, mildew resistant, MIL-B-11743B.		1	1		
					DEPARTMENT OF THE ARMY TECHNICAL MANUAL CANVAS REPAIR KIT TM 10-633.		2	2		
					DEPARTMENT OF THE ARMY OPERATORS AND ORGANIZATIONAL MAINTENANCE MANUAL TM 10-8340-210-13.		2	2		
	P1	O		5120-440-3120	KEY: Socket head, screw, X-type, L-handle, 5/16 in. dia., 6 in. X 6 in.		9	9	3	7
					GROUP 32--BASIC ISSUE ITEMS, TROOP INSTALLED 3200--BASIC ISSUE ITEMS, TROOP INSTALLED OR AUTHORIZED					
	P1	O		8340-182-0435	ANGLE: tie		1	1		
	P1	O		8340-182-0436	ARCH: complete		5	5		
	P1	O		8340-377-6590	BLANKET ASSEMBLY: tent end		2	2	3	3
	P1	O		8340-377-6591	BLANKET ASSEMBLY: tent roof		4	4	2	3
	P1	O		8340-508-0600	CONNECTOR-SWITCH: complete		1	1	12	
	P1	O		8340-182-9300	COVER: end vestibule		1	1	9	4
	P1	O		8340-220-6518	COVER: top vestibule		1	1		
	P1	O		8340-377-6607	FLOOR: runner, tent		16	16		
	P1	O		8340-377-6600	FLOOR: tent vestibule		1	1	1	1
	P1	O		8340-030-1433	BUYBAND ASSEMBLY: tent roof		3	1	7	1
	P1	O		8340-252-2270	LINE: tent		4	4	3	5
	P1	O		8340-377-6604	PANEL AND DOOR ASSEMBLY: tent vestibule		1	1		
	P1	O		8340-261-9748	PIN: tent		24	24	3	6
	P1	O		8340-183-0097	PAULIN: end tent		4	4	3	4
	P1	O		8340-182-9320	PAULIN: end, vestibule		1	1	7	3
	P1	O		8340-359-2554	PAULIN: tent arch		36	36		
	P1	O		8340-377-6605	SIDE PANEL ASSEMBLY: tent vestibule		1	1		

APPENDIX III

MAINTENANCE ALLOCATION CHART

Section I. INTRODUCTION

1. General

a. Section I provides a general explanation of all maintenance and repair functions authorized at various maintenance levels.

b. Section II designates overall responsibility for the performance of maintenance operations on the identified end item or component. The implementation of the maintenance tasks upon the end item or component will be consistent with the assigned maintenance operations.

c. Section III lists the special tools and test equipment required for each maintenance operation as referenced from section II. (Not applicable.)

d. Section IV contains supplemental instructions, explanatory notes and/or illustrations required for a particular maintenance function.

2. Explanation of Columns in Section II

a. *Functional Group Number.* The functional group is a numerical group set up on a functional basis. The applicable functional grouping indexes (obtained from TB 750-93-2 Functional Grouping Codes) are listed on the MAC in the appropriate numerical sequence. These indexes are normally set up in accordance with their function and proximity to each other.

b. *Component Assembly Nomenclature.* This column contains a brief description of the components of each functional group.

c. *Essentiality.* The essentiality column reflects whether or not an assembly, or repair part, is combat essential to the tactical use of the end item. The letter "E" in this column indicates an item is combat essential.

d. *Maintenance Operations and Maintenance Levels.* This column lists the maintenance operations ("A" through "J") and indicates the lowest maintenance level authorized to perform these operations.

The symbol designations for the various maintenance levels are as follows:

- O/C - Operator or crew
- O - Organizational
- DS - Direct Support
- GS - General Support
- D - Depot

The Maintenance Operations are defined as follows:

- A--SERVICE: Operations required periodically to keep the item in proper operating condition, i.e., to clean, preserve, drain, paint, and replenish fuel, lubricants, hydraulic, and deicing fluids, or compressed air supplies.
- B--ADJUST: Regulate periodically to prevent malfunction. Adjustments will be made commensurate with adjustment procedures and associated equipment specifications.
- C--ALINE. Adjust two or more components of an electrical or mechanical system so that their functions are properly synchronized or adjusted.
- D--CALIBRATE: Determine, check, or rectify the graduation of an instrument, weapon, or weapons system or components of a weapons system.
- E--INSPECT: Verify serviceability and detect incipient electrical or mechanical failure by close visual examination.
- F--TEST: Verify serviceability and detect

incipient electrical or mechanical failure by measuring the mechanical or electrical characteristics of the item and comparing those characteristics with authorized standards. Tests will be made commensurate with test procedures and with calibrated tools and/or test equipment referenced in the MAC.

G--REPLACE: Substitute serviceable components, assemblies and subassemblies for unserviceable counterparts or remove and install the same item when required for the performance of other maintenance operations.

H--REPAIR: Restore to a serviceable condition by replacing unserviceable parts or by any other action required using available tools, equipment and skills to include welding, grinding, riveting, straightening, adjusting and facing.

I--OVERHAUL: Restore an item to a completely serviceable condition (as prescribed by serviceability standards developed and published by the commodity commands) by employing techniques of "Inspect and Repair Only as Necessary" (IROAN). Maximum use of diagnostic and test equipment is combined with minimum disassembly during overhaul. "Overhaul" may be assigned to any level of

maintenance except organizational, provided the time, tools, equipment, repair parts authorization, and technical skills are available at that level. Normally, overhaul as applied to end items, is limited to depot maintenance level.

J--REBUILD: Restore to a condition comparable to new by disassembling to determine the condition of each component part and reassembling using serviceable, rebuilt, or new assemblies, subassemblies, and parts.

e. *Reference Note.* This column, subdivided into columns "K" and "L", is provided for referencing the SPECIAL TOOL AND TEST EQUIPMENT REQUIREMENTS (Section III) and REMARKS (Section IV) that may be associated with maintenance operations (Section II).

3. Explanation of Columns in Section III
(Not Applicable)

4. Explanation of Columns in Section IV

a. *Reference Code.* This column consists of two letters separated by a dash, both of which are references to Section II. The first letter

Section II. MAINTENANCE ALLOCATION CHART

Functional Group Number	Component Assembly Nomenclature	Essentiality	Maintenance Operations and Levels										Ref Note			
			A	B	C	D	E	F	G	H	I	J	K	L		
			Service	Adjust	Align	Calibrate	Inspect	Test	Replace	Repair	Overhaul	Rebuild	T&TE RQMT	Remarks		
54	TENTAGE, EQUIPMENT															
5401	Tent Body Body, Tent		O/C	O/C	O	O	A B
5403	Tent Support Components Frame, Tent		O/C	O/C	O	O	C D
5404	Tent Anchoring Components Guyband, Assemblies, Pins and Slips, Lines		O/C	O/C	O	O	E F
5405	Tent Accessories Connector, Switch Lamp		O/C	O/C	O	O	

references column L and the second letter references a maintenance operation, Column "A" through "J".

b. Remarks. This column lists information pertinent to the Maintenance Operation being performed, as indicated on the MAC Section II.

Section III. SPECIAL TOOLS AND TEST EQUIPMENT REQUIREMENTS

No special tools or equipment are required to perform maintenance on the tent.

Section IV. REMARKS

Reference Code	Remarks	Reference Code	Remarks
A-A	Service. Indicates cleaning tent.	D-H	Repair major. Indicates fabrication of parts.
A-H	Repair in O. Indicates hand sewing and cement patching.	E-H	Repair minor. Indicates hand sewing and cement patching.
B-H	Repair in DS. Indicates machine sewing.	F-H	Repair major. Indicates splicing lines machine sewing guyband assemblies.
C-H	Repair minor. Indicates tightening and replacing hardware.		

INDEX

	Paragraph	Page		Paragraph	Page
Appendixes	2	3	Orientation	5	3
Arches and parts:			Preventive maintenance services:		
Fabrication (parts)	43	37	Daily	20	21
Repair	43	37	Quarterly	21	21
Replacement	28	26	Purlins		
Basic issue items	App. II	47	Repair	45	39
Connector-Switch and parts:			References	App. I	45
Repair	48	41	Repair parts and equipment	17	21
Replacement	37	30	Roof blanket assemblies		
Crating the tent	14	19	Repair	40	36
Data, tabulated	7	4	Scope	1	3
Demolition	55, 56	44	Service upon receipt of equipment	8, 9	7, 8
Description	6	3	Shipment	50, 51	43
End blanket assemblies and parts:			Site selection and preparation	11	10
Fabrication (parts)	39	32	Storage	53, 54	44
Repair	39	32	Striking the tent	13	15
Replacement	24	23	Tent floor parts		
Erecting the tent	12	10	Repair	46	39
Guyband assemblies			Replacement	29	27
Repair	47	40	Tent pins, tent slips, and tent guy lines		
Replacement	34	29	Replacement	33	29
Improvement suggestions	4	3	Tools	18	21
Maintenance allocation	App. III	49	Use of tent:		
Maintenance forms, records, and reports	3	3	Unusual conditions	15, 16	19
Maintenance:			Usual conditions	10, 11, 12,13,14	10, 10, 10,15,19
Connector-Switch	36	30	Vestibule end cover and parts and vestibule top cover and parts		
Tent anchoring components	32	29	Repair	41	36
Tent body (user and organizational)		23	Replacement	25	23
Tent body (direct support)	38	32	Vestibule parts		
Tent support components (user and organizational)	27	26	Repair	44	38
Tent support components direct support)	42	37	Replacement	30	28

By Order of the Secretary of the Army:

HAROLD K. JOHNSON,
General, United States Army,
Chief of Staff.

Official:

J. C. LAMBERT,
Major General, United States Army,
The Adjutant General.

Distribution:

Active Army:

USASA (1)	Mob Equip Manuals Fld Ofc (2)
DCSLOG (1)	Ft Lee
CNGB (1)	USASPTCP (10)
C/Army Res (1)	USA Mob Spt Cen (46)
CofSptS (1)	Svc Colleges (2)
CofEngrs (6)	Br Svc Sch (2 except
Dir of Trans (1)	USAQMS (10)
CC-E (1)	USAQMTC Library (4)
USAMC (12)	USMA (1)
USASMC (1)	Army Dep (4)
USAMICOM (5)	PG (2)
USAWECOM (5)	Arsenals (.)
USAMUCOM (5)	POE (2)
USAECOM (5)	USA Tml Comd (2)
USATECOM (5)	Army Tml (2)
USAMOCOM (2)	QM Fld Maint Shops (2)
USCONARC (2)	Units org under fol TOE:
ARADCOM (2)	(2 copies each)
ARADCOM Rgn (2)	10-105
OS Maj Comd (3)	10-107
LOGCOMD (1)	10-347
Instls (2)	10-348
MDW (1)	10-445
Armies (5)	10-448
Natick Lab (4)	

NG: None.

USAR: None.

For explanation of abbreviations used, see AR 320-50.

☆ U.S. GOVERNMENT PRINTING OFFICE: 1995 - 388-421/01480

The Metric System and Equivalents

Linear Measure

1 centimeter = 10 millimeters = .39 inch
 1 decimeter = 10 centimeters = 3.94 inches
 1 meter = 10 decimeters = 39.37 inches
 1 dekameter = 10 meters = 32.8 feet
 1 hectometer = 10 dekameters = 328.08 feet
 1 kilometer = 10 hectometers = 3,280.8 feet

Weights

1 centigram = 10 milligrams = .15 grain
 1 decigram = 10 centigrams = 1.54 grains
 1 gram = 10 decigrams = .035 ounce
 1 decagram = 10 grams = .35 ounce
 1 hectogram = 10 decagrams = 3.52 ounces
 1 kilogram = 10 hectograms = 2.2 pounds
 1 quintal = 100 kilograms = 220.46 pounds
 1 metric ton = 10 quintals = 1.1 short tons

Liquid Measure

1 centiliter = 10 milliliters = .34 fl. ounce
 1 deciliter = 10 centiliters = 3.38 fl. ounces
 1 liter = 10 deciliters = 33.81 fl. ounces
 1 dekaliter = 10 liters = 2.64 gallons
 1 hectoliter = 10 dekaliters = 26.42 gallons
 1 kiloliter = 10 hectoliters = 264.18 gallons

Square Measure

1 sq. centimeter = 100 sq. millimeters = .155 sq. inch
 1 sq. decimeter = 100 sq. centimeters = 15.5 sq. inches
 1 sq. meter (centare) = 100 sq. decimeters = 10.76 sq. feet
 1 sq. dekameter (are) = 100 sq. meters = 1,076.4 sq. feet
 1 sq. hectometer (hectare) = 100 sq. dekameters = 2.47 acres
 1 sq. kilometer = 100 sq. hectometers = .386 sq. mile

Cubic Measure

1 cu. centimeter = 1000 cu. millimeters = .06 cu. inch
 1 cu. decimeter = 1000 cu. centimeters = 61.02 cu. inches
 1 cu. meter = 1000 cu. decimeters = 35.31 cu. feet

Approximate Conversion Factors

To change	To	Multiply by	To change	To	Multiply by
inches	centimeters	2.540	ounce-inches	Newton-meters	.007062
feet	meters	.305	centimeters	inches	.394
yards	meters	.914	meters	feet	3.280
miles	kilometers	1.609	meters	yards	1.094
square inches	square centimeters	6.451	kilometers	miles	.621
square feet	square meters	.093	square centimeters	square inches	.155
square yards	square meters	.836	square meters	square feet	10.764
square miles	square kilometers	2.590	square meters	square yards	1.196
acres	square hectometers	.405	square kilometers	square miles	.386
cubic feet	cubic meters	.028	square hectometers	acres	2.471
cubic yards	cubic meters	.765	cubic meters	cubic feet	35.315
fluid ounces	milliliters	29.573	cubic meters	cubic yards	1.308
pints	liters	.473	milliliters	fluid ounces	.034
quarts	liters	.946	liters	pints	2.113
gallons	liters	3.785	liters	quarts	1.057
ounces	grams	28.349	liters	gallons	.264
pounds	kilograms	.454	grams	ounces	.035
short tons	metric tons	.907	kilograms	pounds	2.205
pound-feet	Newton-meters	1.356	metric tons	short tons	1.102
pound-inches	Newton-meters	.11296			

Temperature (Exact)

°F	Fahrenheit temperature	5/9 (after subtracting 32)	Celsius temperature	°C
----	------------------------	----------------------------	---------------------	----

